

ATECH

Serving North America since 2002

www.ATechMachinery.com



ZIGMA – 550FA

TAM OTOMATİK CNC ÇİFT KAFA KESME MAKİNESİ
KULLANMA KILAVUZU

—

FULL AUTOMATIC CNC DOUBLE HEAD SAW MACHINE
USER'S MANUAL



CONTENTS

	<u>Page No</u>
1. GENERAL INFORMATION	2
1.1. Introduction	2
1.2. Information About The Manufacturer	2
2. MACHINE'S DESCRIPTION AND PURPOSE OF USE	2
2.1. Machine's Description	2
2.2. Technical Features	2
2.3. Cutting Diagram	3
2.4. Dimensions	3
3. SAFETY	4
3.1. Safety Information	5
3.2. Accident Prevention	5
3.3. General Safety Information	5
3.4. Safety Symbols And Meanings	5
4. TRANSPORT OF THE MACHINE	5
5. INSTALLATION OF THE MACHINE	5
5.1. Preparation	5
5.2. Instructions About Safe Connection Of The Machine To The Power Source	5
5.3. Air Pressure Setting	6
6. MACHINE SAFETY DATA	6
7. OPERATION	6
7.1. Panel Promotion and Program Entry	7
7.2. Automatic Cutting	7
7.2.1. Recipe	8
7.3. Manual Cutting	8
7.4. Slicing	8
8. SAFE INSTALLATION OF THE SAW BLADE	9
9. MAINTENANCE, SERVICE AND REPAIR	9
9.1. Periodic Checks And Starting To Work	9
9.2. Maintenance At The End Of The Working Day	9
10. TROUBLESHOOTING GUIDE	9
11. COMPONENTS	10
11.1. Electric Components	10
11.2. Hydraulic-Pneumatic Components	10

1. GENERAL INFORMATION

1.1. Introduction

The user's manual given by the manufacturer contains information about the machine parts. Each machine operator should read these instructions carefully, and the machine should be operated after fully understanding them.

Safe and efficient use of the machine for long term depends on understanding and following the instructions contained in this manual. The technical drawings and details contained in this manual constitute a guide for the operator.

1.2. Information About The Manufacturer

ATECH MAKINE SAN. ve TIC.LTD. STI.

Address : www.atech.com.tr

Tel. : +90 216 31 444 33

e-mail : info@atech.com.tr

*In case of any technical problem please contact your nearest ATECH dealer or ATECH head office through the above mentioned phone, fax or e-mail address.

*Technical labels with the model description of the machine are fixed onto the front side of each machine.

*The machine's serial number and manufacturing year are stipulated on the technical label.

2. MACHINE'S DESCRIPTION AND TECHNICAL FEATURES

2.1. Machine's Description

Double head automatic saw machine for cutting of PVC, aluminum and wooden profiles in desired angles. The operator has the possibility to adjust the cutting speed of the saw blade via knob according to material type and size. Machine features:

- Aluminum and PVC profiles can be cut in the desired length as straight and angled cuts.
- The head can be adjusted automatically at -22,5° and 45°.
- Moving on precision rails with the help of right head servo motor, pneumatic brake and conveyor.
- Both cutting units provide more rigid and precise cutting thanks to two front-end clamping systems.
- Dual hand safety system available.
- Provides maximum safety thanks to the protective caps.
- The cutting unit is hydro-pneumatic and the cutting speed can be precisely adjusted according to the type of material to be cut.
- Touchscreen with operator control panel.
- Slicing, angle slicing, pieces of cutting profiles list and etc. are programmable
- 45° Cutting Capacity min.: 595 mm, max.: 5050 mm
- 90° Cutting Capacity min.: 390 mm, max.: 5050 mm
- Oil spray system is available.

STANDARD ACCESSORIES

- 2 x Ø550 mm. Carbide tipped saw blade
- 4 pcs. Horizontal clamps
- Spray lubrication system
- Airgun
- 2 pcs. Conveyor
- 2 pcs. Profile rest system







OPTIONAL ACCESSORIES

- Barcode reader
- Spray mist lubrication system
- 2 pcs. Vertical clamps
- Chip collector manifold
- 4 kW electric motor

Please mention the below mentioned data in all your correspondence regarding the machine with the manufacturer and/or your ATECH dealer.

- Machine model
- Machine's serial number
- Voltage and frequency
- Name of dealer where machine was purchased
- Date of purchase
- Description of the machine fault
- Average daily operation period

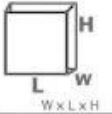
2.2. Technical Features

						
2x3,0kW Motor 3x1,0 kW Servo Motor Total: 9,0 kW 50/60Hz	D=550 mm d=30-32 mm	3000 r.p.m.	BAR 6-8 Bar	Air cons. 100lt./min	713x195x192 cm	1800

2.3. Cutting Diagram

Zigma FA-550

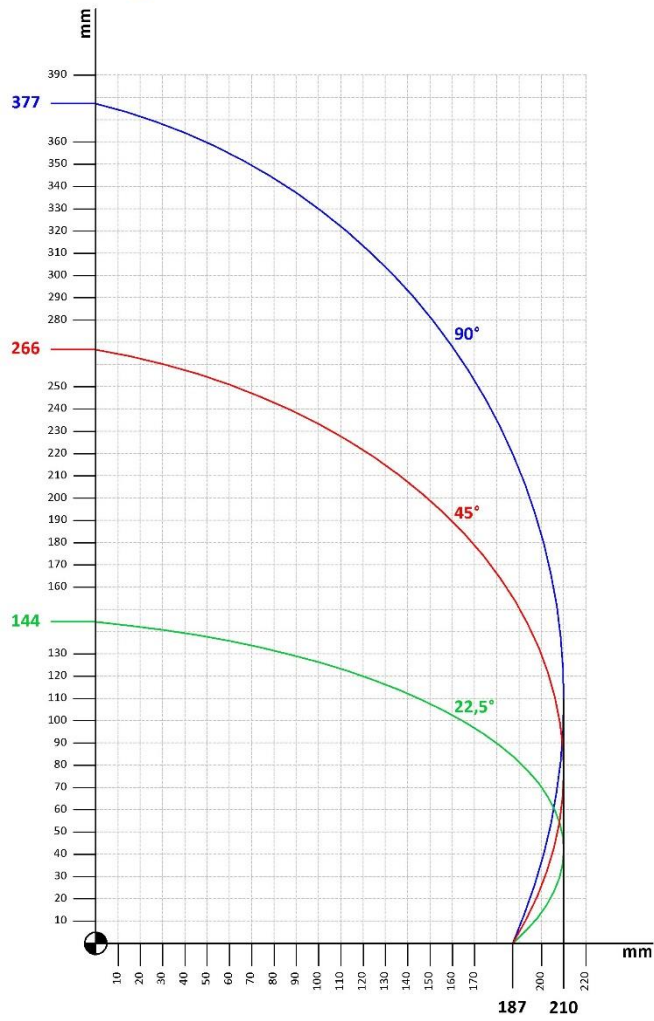

2.4. Dimensions

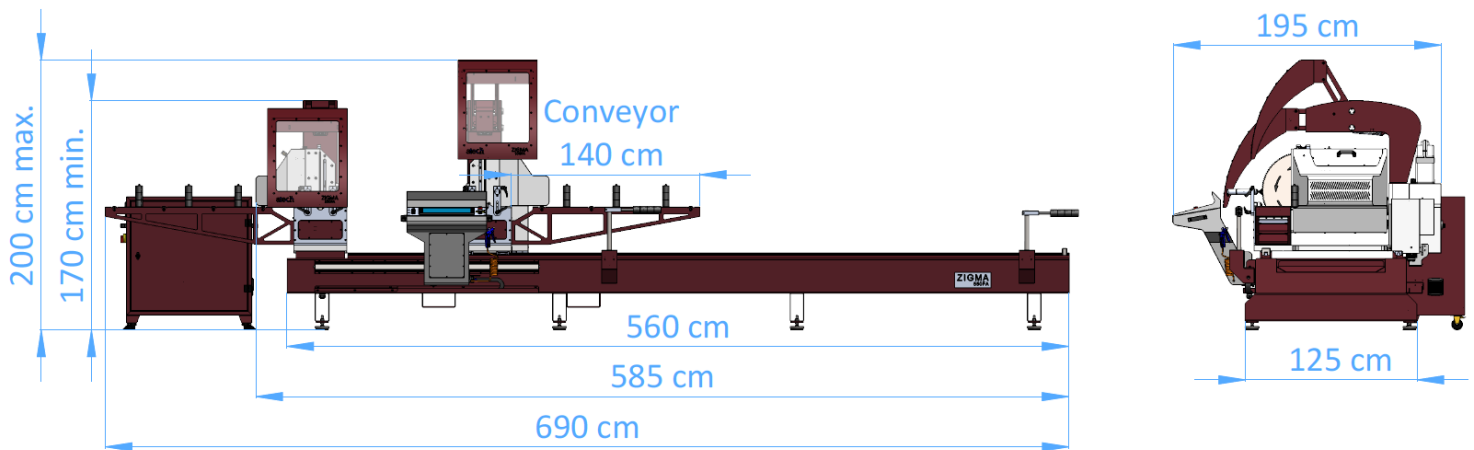

3. SAFETY

3.1. Safety Information

The symbols shown hereunder are necessary to be read with special attention.

Not reading or observing of them may cause damage to the equipment or personal injury.

IMPORTANT

The **IMPORTANT** symbol above is one telling to apply special care and to be careful at carrying out the specified operation.

CAUTION!

The **CAUTION!** symbol above warns you against specific dangers and requires to read the text. Not observing may cause damage to the equipment.



The above symbol **DANGER WARNING**, warns you against specific dangers and you have definitely to read them. Negligence may cause damage to the equipment and bodily injury. Read the user's manual carefully before using the machine or carrying out maintenance works.



3.2. Accident Prevention

- 3.2.1. Our machines are manufactured in accordance with EN 60204–1 and EN 292–2 CE safety directives, which cover national and international safety directives.
- 3.2.2. It is the task of the employer to warn his staff against risks, to train them on prevention of accident, to provide for necessary safety equipment and devices for the operator's safety.
- 3.2.3. Before starting to work with the machine, the operator should check the features of the machine, learn all details of the machine's operation.
- 3.2.4. Machine should be operated only by staff members, who have read and understood the contents of this manual.
- 3.2.5. All directives, recommendations and general safety rules contained in this manual have to be observed fully. The machine cannot be operated in any way for purposes other than those described herein. Otherwise, the manufacturer shall not be deemed responsible for any damages or injuries. And such circumstances would lead to the termination of the warranty.

3.3. General Safety Information











- 3.3.1. The power cable should be led in such a way that nobody can step on it or nothing can be placed on it. Special care be taken regarding the inlet and outlet sockets.
- 3.3.2. If the power cable should be damaged during operation, don't touch and unplug it. Never use damaged power cables.
- 3.3.3. Don't overload machines for drilling and cutting. Your machine will operate more safely with power supply in accordance with the stipulated values.
- 3.3.4. Don't place your hands between parts in motion.
- 3.3.5. Use protective eye glasses and ear plugs. Don't wear oversized clothes and jewels. These can be caught by moving.
- 3.3.6. Keep your working place always clean, dry and tidy for accident prevention and safe operation.
- 3.3.7. Use correct illumination for the safety of the operator. (ISO 8995-89 Standard The Lighting of Indoor Work System)
- 3.3.8. Don't leave anything on the machine.
- 3.3.9. Don't use any materials other than those recommended by the manufacturer for cutting operations on the machine.
- 3.3.10. Ensure that the work piece is clamped appropriately by the machine's clamp or vice.
- 3.3.11. Ensure safe working position, always keep your balance.
- 3.3.12. Keep your machine always clean for safe operation. Follow the instructions at maintenance and replacement of accessories. Check the plug and cable regularly. If damaged, let it be replaced by a qualified electrician. Keep handles and grips free of any oil and grease.
- 3.3.13. Unplug first, before conducting maintenance works.
- 3.3.14. Ensure that any keys or adjustment tools have been removed before operating the machine.



- 3.3.15. If you are required to operate the machine outside, use only appropriate extension cables.
- 3.3.16. Repairs should be carried out by qualified technicians only. Otherwise, accidents may occur.
- 3.3.17. Before starting a new operation, check the appropriate function of protective devices and tools, ensure that they work properly. All conditions have to be fulfilled in order to ensure proper operation of your machine. Damaged protective parts and equipment have to be replaced or repaired properly (by the manufacturer or dealer).
- 3.3.18. Don't use machines with improperly functioning buttons and switches.
- 3.3.19. Don't keep flammable, combustible liquids and materials next to the machine and electric connections.

3.4. Safety Symbols And Meanings

	Electric warnings.		Use protective goggles.
	If main connection cable is damaged during operation, do not touch it and disconnect the main plug from main socket.		Use protective earmuffs.
	When machine is working, do not make your hand close to saw blade.		Use protective gloves when changing the saw.
	Keep working environment clean, dry and tidy.		Read operating instructions carefully before using or maintaining the machine.

4. TRANSPORT OF THE MACHINE

IMPORTANT

* The transport should be done by qualified personnel only.

- 4.1.1. The machine should be transported by lifting with proper equipment (not touching the ground during the transport).
- 4.1.2. Don't lift the machine before ensuring that lifting devices or other equipment is placed properly under the machine.
- 4.1.3. For the weight and dimensions of the machine, 2.2. Technical Features

5. INSTALLATION OF YOUR MACHINE

The machine should be located at least 50 cm in front of the back wall. The machine is equipped with a burr collection bag connector and power supply socket on the back side.

The left side of the fixed head should be left 100 cm in accordance with the length of the profile material to be cut, and 200 cm space should be left on the right side of the moving head.

5.1. Preparation

- 5.1.1. The outer dimensions of the machine are stipulated in the dimensions page. The ground, where the machine will be placed, should be even, solid enough to bear the weight of the machine.
- 5.1.2. At the double head automatic saw machine Zigma all parts are delivered by the manufacturer ready for use.

Do not make electrical connections without removing the bolt and stop connections used for the detection of running systems before the machine is started and without wiping the protective oil layer in working parts.

5.2. Instructions For Safe Connection Of The Machine To The Power Source

- 5.2.1. The three-phase electrical cable socket must have five inputs to the cable on the machine.
- 5.2.2. Use a connection cable sockets in accordance with the CE Safety Directives.
- 5.2.3. Check the inlet power supply before powering the machine.

CAUTION!

The socket connections have to be made by a qualified electrician, the rotation direction of the saw blade has to be observed by starting the machine. If the saw blade rotates in reverse direction, the socket connections have to be checked and re-connected properly.

If the saw blade rotates in reverse direction, it will cause danger for the operator and the equipment.

To correct the rotation direction of the saw blade, plug in the machine and follow these instructions:

1. Turn on the main switch and open the manual cutting page on the screen.
2. Press the motor button on the control panel to start one of the motors.
3. Press the same motor button again to stop the engine. Observe the rotation of the saw from the saw output channel.

If the saw blade rotates in reverse direction: The electric socket connections have to be checked and corrected by a qualified electrician. The direction of rotation of the saw must not be run without testing.

5.3. Air Pressure Setting

For the pneumatic system to operate properly, the air pressure must be 6-8 bars. **Do not operate at lower pressures than 6 bars.** Read the manometer on the conditioner to calibrate and check the air pressure.

Follow the steps below for air pressure settings.

- 5.3.1. Pull up the conditioner adjustment knob.
- 5.3.2. The pressure increases when the knob is turned clockwise, while the pressure decreases when it is turned counter-clockwise.
- 5.3.3. When you read the 6-8 Bar pressure setting on the pressure gauge, lock the conditioner setting knob.
- 5.3.4. The conditioner unit accumulates the water contained in the air system into the collection container so as not to damage the pneumatic system components. Automatically removes water collected when air is supplied to the machine.
- 5.3.5. The oil recommended by the manufacturer in the conditioner is TELLUS C 10 / BP ENERGOL HLP 10 / MOBIL DTE LIGHT / PETROL OFFICE SPINDURA 10.

6. MACHINE SAFETY DATA

- 6.1.1. It is not allowed to operate the machine with the protective cover and other protective equipment removed.
- 6.1.2. Use your machine at the voltage values specified on the technical label. Let the electric installation of your machine carry out by a qualified electrician only. Grounding must be done. There will be irregularities in machine operation if grounding is not done properly.
- 6.1.3. Lifting, installation, electric, pneumatic maintenance of the machine should be carried out by qualified personnel only.
- 6.1.4. Routine maintenance and scheduled maintenance should be carried out by qualified personnel after unplugging the machine and disconnecting the air supply first.
- 6.1.5. Ensure that the machine has been cleaned, tested and maintenance before starting to operate.
- 6.1.6. Check the safety devices, power cable and moving parts regularly. Don't operate the machine before having replaced defective safety devices or faulty parts
- 6.1.7. Never replace the circular saw without disconnecting the air and the electrical power connection.
- 6.1.8. Keep foreign materials away from the working area of the machine, keep away from the machine's moving parts.

IMPORTANT

The saw blade continues its rotation for a while after switching off the motor.

CAUTION!

Don't use the machine for purposes other than it has been designed for (cutting of iron and other ferrous materials).

IMPORTANT

The safety data have been defined above. In order to prevent physical damage or damage to the equipment, please read the safety information carefully and keep the manual always in an easy accessible place.

7. OPERATION

Zigma double head automatic cutting machine cuts products made of non-ferrous aluminum, wood and PVC type. The inner and outer sharp edges of the circular saw allow you to achieve a high quality smooth surface.

With the help of the servo motor located on the moving head of the Zigma double head automatic cutting machine, the dimensions of the work piece to be cut are obtained by finding the position in the most precise way. As it has the ability to do its approach to measurement with the help of the program in the same direction, it eliminates all measurement errors caused by the gap.

7.1. Panel Promotion and Program Entry

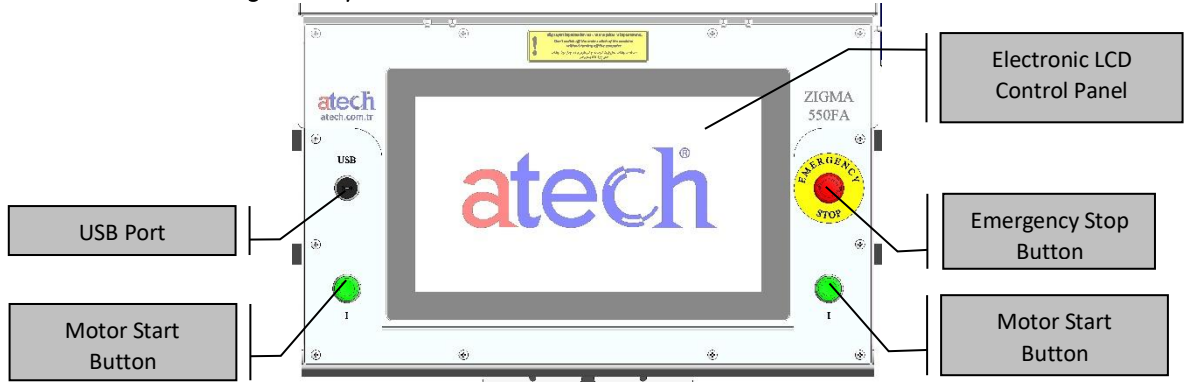

Zigma Double Head Automatic Cutting Machines Using electronic positioning device;



OFF



ON

- a) Set Main Switch to "1".



- b) Change your language selection by pressing the "SETTINGS" button.

7.2. Automatic Cutting

When you want to trade in the automatic cutting, you can cut the measurements you have prepared earlier by selecting from the "CUT LIST" or cutting them with the new cut values that you will created from "RECIPE".

You can access the desired values by using arrow keys next to the cutting list sequence number display to go to the measurement values available in the CUTTING LIST. When you reach the desired value, press **START** button to send to demanded measurement. After moving the moving head to the desired measurement, press **CLAMP BUTTON** to fix workpiece. Press **Motor Start Buttons** to switch on motors. Press both **Cutting Buttons** to start cutting. Keep pressing the buttons until cutting process finishes. After cutting process finishes, pull hand pressure on the buttons. Saws will automatically return to their original position. After the cutting process is finished, the clamps will open automatically, you can get your profile.

IMPORTANT

NOTE: When the written value is completed during the cutting process, the machine will automatically switch to the next recipe and wait for you to press "START" button.

NOTE: In terms of employee safety, the cutting process is adapted to two-hand operation. The head moves on the group working in the cutting operations performed on the single head. The other cutting group unit remains stationary.

NOTE: In our machine, you can make automatic cutting of workpieces longer than 4100 mm. Max. workpieces up to 7000 mm can be cut. Workpieces with lengths from 4100 to 7000 mm cannot be cut with two heads at the same time as

they pass the length of the machine. However, the desired measure can be cut with our own software. When you type the desired size and press the "GO" button, the moving head moves to the maximum size. Press the "Clamp button" to tighten the workpiece. When the workpiece is tightened, the forehead cleaning takes place automatically from the fixed head without waiting for any commands. After the cutting processes of the fixed head, the moving head moves back to the limit measurement by driving the profile as far as the missing dimension. Here you must start the moving head motor and cut it by pressing the two hand buttons. Press the cutting buttons for the next cut.

7.2.1. Recipe



When you press the **Recipe button**, you can create a new recipe or you can make changes by changing the values by accessing the values you have prepared before. To create a new recipe, fill in the appropriate places.

7.3. Manual Cutting

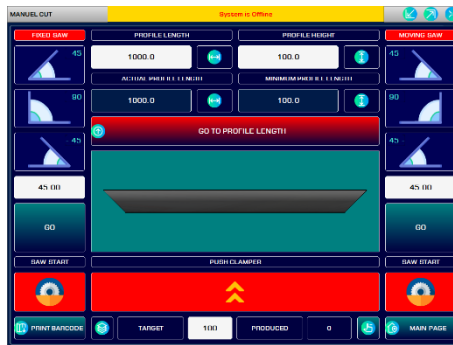

When you want to cut with **MANUEL CUT**, type desired workpiece measures in **DIMENSION TO GO** section. If the angle you want to cut is 45° or 90°, press the corresponding button. For intermediate angles set them manually. After setting the cutting measure and cutting angle, press **GO** button. After the moving head moves to desired measure, press the **Push Clamper** to fasten up the workpiece. Press the **Saw Start** to start the motors. Press both **Cutting Buttons** to start cutting. Keep pressing **Cutting Buttons** until cutting process finishes. After the cutting process is finished, the clamps will open automatically, you can get your profile

7.4. Slicing



In the slicing section, it provides automatic cutting to the desired size, equal length and desired number of work pieces. The length of the workpiece to be sliced is written on **"MATERIAL LENGTH"**. Write the desired length value of the workpiece to be sliced in the **"ITEM LENGTH"** section. Write the angle values that you want to cut into the **"SET FIRST ANGLE"** and **"SET SECOND ANGLE"** sections. How many pieces will be cut is written in **"TARGET ITEM COUNT"**. **"MATERIAL HEIGHT"** value is

entered and it is sent to the starting position by pressing "GO". After pressing the "Clamp button", the cutting process will start automatically. The cutting process will continue until the specified number of pieces has been completed. When the workpiece on the machine is finished, the machine will stop to the stop position and wait for you to press the "GO TO PROFILE LENGTH" button. When you press "GO TO PROFILE LENGTH" and place the new profile, press the PUSH CLAMPER to continue the operation. If you want to stop cutting or exit the page while the slicing process is in progress, press "STOP" button and wait for the machine to stop. When the machine is stopped, you can leave the page and switch to another page or the machine can continue slicing by pressing the "PAUSE" button again.

8. SAFE INSTALLATION OF THE SAW BLADE

To remove the circular saw blade from the saw mill, apply the following sequence.

- 7.3. Cut off the machine's electrical and air connection.
- 7.4. Remove the saw casing cover.
- 7.5. While holding the saw shaft with 8 mm allen, remove the sawing nut with 36 wrenches.
- 7.6. Remove the saw flange.
- 7.7. Carefully remove the saw.
- 7.8. Install the new saw on the shaft by checking that the direction of rotation is correct.
- 7.9. Replace the dismantled parts in accordance with the order of dismantling.
- 7.10. Tighten the sawing nut with 36 wrenches while keeping the saw shaft fixed with 8 mm allen.
- 7.11. It is necessary to sharpen / replace the saw blade in certain intervals depending on the cutting material. If the cut material leaves burr after the cutting operation or if the saw blade is strained, it needs to be sharpened / replaced.

CAUTION!

When replacing the saw with a new one, use the saw blade that corresponds to the saw blade diameter. The outer diameter of the saw ring is two parts according to 30 and 32 mm.

9. MAINTENANCE SERVICE AND REPAIR

9.1. Periodic Checks And Starting To Work

- 9.1.1. Make sure that the both cutting table and all parts are clean and dry. Clean the tray from the oil and dry it. Be especially sure of the cleanliness and installation of the gripper handles.
- 9.1.2. Clean all surfaces of the machine from the bulges, from the chips and foreign materials. Use glasses to protect yourself from harmful substances.
- 9.1.3. Check the saw blade against wear, bending, cracking and breakage before each use. Turn your hands carefully (after lifting the protective housing up) to see each tooth of the saw blade. If the saw is damaged, replace the saw.
- 9.1.4. Check the air pressure system pressure. Set the air pressure around 6-8 bar if necessary.
- 9.1.5. Check the air pressure filters and the oil level in the conditioner. If the amount of fat is missing, complete it.

Note : Disconnect the electrical power connection and the air pressure connections before doing all this.

9.2. Maintenance At The End Of The Working Day

- 9.2.1. Unplug the machine.
- 9.2.2. Remove all burr, chip and foreign materials from the machine surfaces. Use gloves to protect your hands from the sharp edges of the blade.
- 9.2.3. Don't use materials for cleaning the machine, which could damage its paint.
- 9.2.4. If water and water based liquids are used during the cutting process, dry the machine and rails with dry cloth at the end of the work and lubricated
- 9.2.5. Apply a thin layer of grease to the plate to protect it from corrosion. If it will not be used for a long time, lubricate with a protective oil.
- 9.2.6. Lubricate both surfaces of the saw blade with machine oil in order to protect it against corrosion.

10. TROUBLESHOOTING GUIDE

Here are our suggestions to get rid of immediate problems. If the fault can not be rectified or if you encounter a fault other than those listed below, please contact the technical service.

TROUBLES	CAUSES	REMEDY
Low surface quality (at aluminum and similar materials); <ul style="list-style-type: none"> • Rough surface, • Large chip, • Not homogenous surface, • Saw blade traces visible 	Not cooling the saw blade surfaces.	Lubricating the saw blade cutting surfaces, Using of cooling liquid.
	Using of damaged or blunt saw blade or the saw rotating in reverse.	Check the saw blade teeth. Replace if necessary. Check the electricity.
	Saw blade moves to quick.	The cutting speed is too high fort he material. Decrease the cutting speed.
Motor does not work (Start button is pressed, not working)	No power supply to the machine.	Check the electric cable connections. Check the electric power sockets.

Motor is working but the pneumatic clamp piston do not work.	The air supply connections are missing, or the air pressure is too low.	Check the air compressor connections. Adjust the air pressure between 6-8 Bar on the conditioner.
The saw blade rotates in reverse direction.	The electric connection or the power cable is wrong.	Let the electric connections carry out by a qualified electrician.

11. COMPONENTS

1. ELECTRIC COMPONENTS

PART NAME	QTY
ELECTRIC MOTOR	2
SERVO MOTOR	3
POWER CABLE 4x2,5 mm	3,5 m

2. HYDRAULIC-PNEUMATIC COMPONENTS

PART NAME	QTY
FRC 1/4 D MINI CONDITIONER	1
VALVE	9
PNEUMATIC HORIZONTAL CLAMPS	4
DMC - A Ø50 x 230 PNEUMATIC CYLINDER	2
DMC Ø50 x 100 PNEUMATIC CYLINDER	2
KS Ø32 x 100 PNEUMATIC CYLINDER	2
HYDRAUCHECK	2
PNEUMATIC VERTICAL CLAMPS	4
SPC Ø50 - 25	2