

**GENERAL FEATURES**

- This saw has been designed to minimize the cut off size
- Safety is ensured in the working area thanks to the pneumatically operated safety guard.
- Hydro-pneumatic V sawing head infinitely adjustable according to the profile
- Manual adjustable back fence working in T slot mechanism
- Double hand safety operation
- External adjustment of hydro-pneumatic saw blade feed
- Pneumatic spray mist lubrication system (optional)
- 90 degree notching operation (optional)

**END NOTCHING MACHINE**



**CUTTING DIAGRAM**

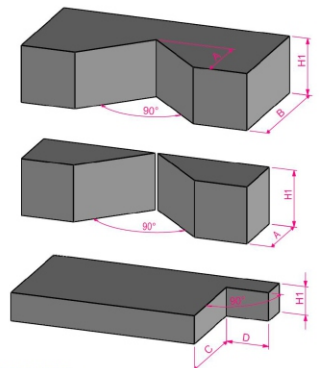





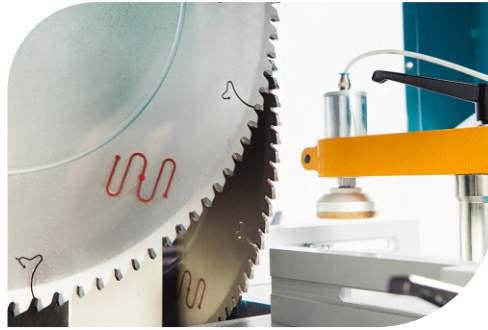



CUTTING DIAGRAM (max.mm)

A	B	H1	C	D
105 (4.1")	Max. 210 (8.3")	230 (9")	150 (6")	150 (6")



**TECHNICAL TABLE**

 2 x 2.2 kW 50/60 Hz 400V P	 2750 D/dk. RPM	 D : 420 mm d : 30/32 mm	 6-8 Bar	 50 lt./dak. Lt./min.	 W : 89 L : 115 H : 186	 410 KG	 360 KG
---	--	---	--	--	---	---	---

