



COMPUTERIZED CONVEYOR

USER'S MANUAL

TECHNICAL FEATURES

			kg	kg
SKN 302	250 W 50 Hz 230V AC N PE	W = 47 L = 308 H = 30	105	165
SKN 452	250 W 50 Hz 230V AC N PE	W = 47 L = 458 H = 30	144	231
SKN 602	250 W 50 Hz 230V AC N PE	W = 47 L = 608 H = 30	189	301

DIMENSIONS

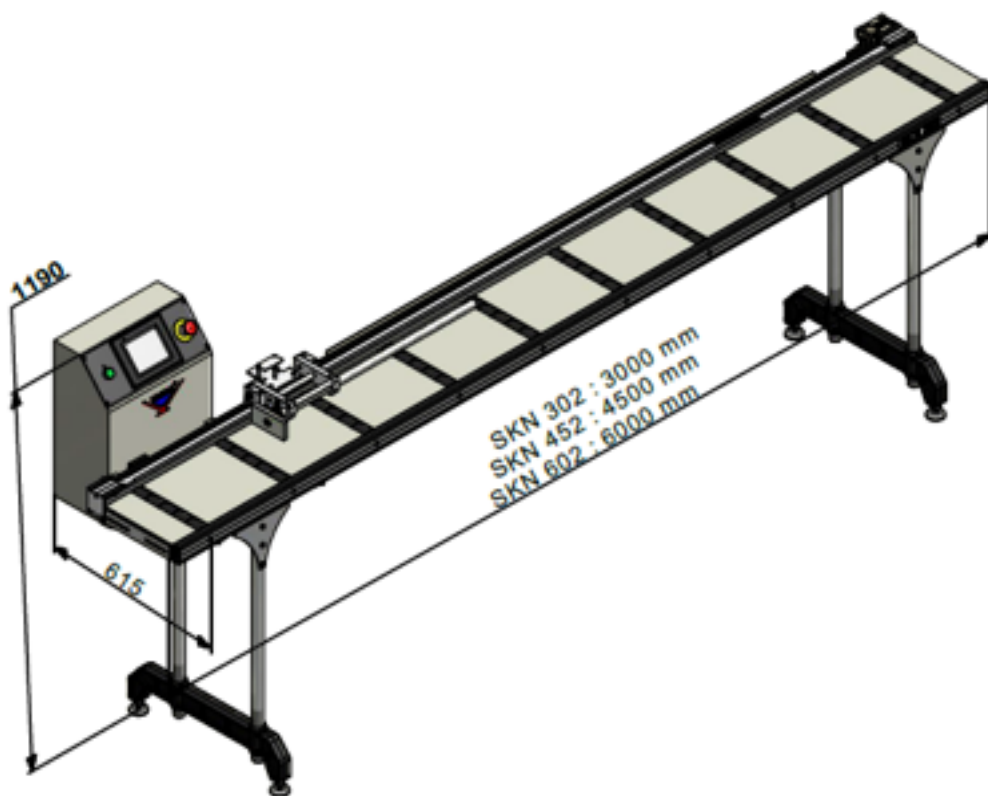

PARTS LIST

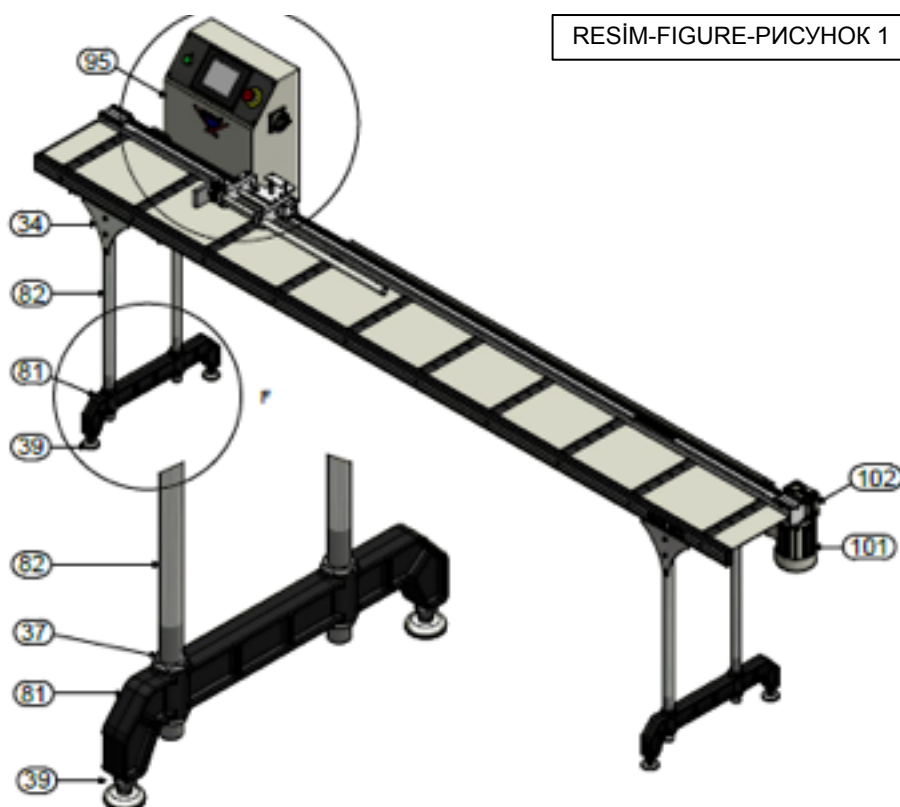

RESIM-FIGURE-РИСУНОК 1

NO	CODE	QTY	NO	CODE	QTY
1	2TU012310-0029	1	101	1EL070001-0011	1
24	2TU011110-0844	1	102	1EL070030-0004	1
25	2TU011210-0390	1	103	1SR070000-0020	1
27	1SC151000-0026	2	104	2TU011110-0146	1
33	1SC011000-0012	5	105	2TU012610-0061	1
34	2TU011441-0321	4			
36	1SC011000-0011	13			
37	2TU011110-0741	8			
39	1SC170000-0007	4			
41	2TU011441-0307	1			
42	2TU012310-0032	1			
55	2TU011441-0322	1			
56	2TU011441-0323	1			
64	2TU013110-0054	50			
76	2TU012210-0456	1			
81	2TU012510-0321	2			
82	2TU011110-0845	4			
85	1SC201000-0001	29			
95	3UA010030-0082	1			
95-1	1EL010000-0046	1			
95-2	1EL090000-0001	1			
95-3	1EL090000-0003	1			
95-4	1EL190000-0013	1			

SPARE PARTS LIST

PART NO	PICTURE	CODE	PART NAME
95-1		1EL010000-0046	MAIN SWITCH
95-2		1EL090000-0001	EMERGENCY STOP BUTTON
95-3		1EL090000-0003	START BUTTON
95-4		1EL190000-0013	LCD SCREEN
		1EL180000-0006	POWER SUPPLY
		1EL020000-0028	SWITCH M5-B1
		1EL020000-0029	SWITCH M5-B2
		1EL050000-0025	RELAY (RT 424730 230V)
		1EL050000-0034	RELAY (RT 424012 12V DC)
		1EL200000-0259	SENSOR (LMIX2-0000-0.8-01-00)

103		1SR070000-0020	BELT
-----	---	----------------	------

CONTENTS

- 1. General information**
 - 1.Introduction
 - 2.Service Information
- 2. Safety**
 - 1.Safety Symbols and Their Meanings
 - 2.Accidents Prevention
 - 3.General Safety Information
- 3. Machine's Description**
- 4. Transport of the Machine**
- 5. Installation of the Machine**
 - 1.Preparation
 - 2.Communication Between Machine and Conveyor
 - 3.Connecting to Power Source
- 6. Machine's Safety Information**
- 7. Operation**
 - 1. Preparation
 - 2. Operation
- 8. Maintenance, Service and Repair**
 - 1. Maintenance
- 9. Warranty Conditions**

1.GENERAL INFORMATION

1. Introduction

The user's manual given by the manufacturer contains necessary information about the machine parts. Each machine operator should read these instructions carefully, and the machine should be operated after fully understanding them.

Safe and efficient use of the machine for long term depends on understanding and following the instructions contained in this manual. The technical drawings and details contained in this manual constitute a guide for the operator.

2. Service Information

In case of any technical problem please contact your nearest ATech dealer, or ATech head office through the above mentioned phone, fax or e-mail address.

Technical labels with the model description of the machine are fixed onto the front side of each machine.

The machine's serial number and manufacturing year are stipulated on the technical label.

Average life usage of production is 10 years. If you have any further failure and complaint, please inform to our below mentioned technical service by verbal or written

AUTHORIZED TECHNICAL SERVICE CENTER ADDRESS

309 Ridgemont Ave., Rockville, MD 20850 - USA

Tel 240-505-1967

Fax 301-560-6627

E-mail info@ATechMachinery.com













Web www.ATechMachinery.com

To minimize the documentation, It is necessary to mention below details at the agreements signed with suppliers and dealers of the purchased machines

• Machine model	• Voltage and frequency
• Machine's serial number	• Date of purchase
• Description of the machine fault	• Name of dealer where machine was purchased
• Average daily operation period	

2. SAFETY

1. Safety Symbols and Their Meanings

	Read the user guide		Ensure safe working position, always keep your balance.
	Wear ear protectors		Elektrical excitation
	Wear safety goggles		Don't place your hands between parts in motion..
	If the power cable should be damaged during operation, don't touch and unplug it. Never use damaged power cables.		High temperature warning
	During saw blade change operations, use protective gloves		Keep your fingers clear of the movable parts of the glide arm.
	The above symbol DANGER WARNING , warns you against specific dangers, and you have definitely to read them..		The IMPORTANT symbol above is one telling to apply special care and to be careful at carrying out the specified operation

2. Accidents Prevention



1. Our machines are manufactured in accordance with CE safety directives, which cover national and international safety directives.
2. It is the task of the employer to warn his staff against accident risks, to train them on prevention of accidents, to provide for necessary safety equipment and devices for the operator's safety.
3. It is the task of the employer to warn his staff against accident risks, to train them on prevention of accidents, to provide for necessary safety equipment and devices for the operator's safety.
4. Machine should be operated only by staff members, who have read and understood the contents of this manual.
5. All directives, recommendations and general safety rules contained in this manual have to be observed fully. The machine cannot be operated in any way for purposes other than those described herein. Otherwise, the manufacturer shall not be deemed responsible for any damages or injuries. And such circumstances would lead to the termination of the warranty

3. General Safety Information

1. The power cable should be led in such a way that nobody can step on it or nothing can be placed on it. Special care has to be taken regarding the inlet and outlet sockets
2. Don't overload machines for drilling and cutting. Your machine will operate more safely with power supply in accordance with the stipulated values.
3. Use correct illumination for the safety of the operator. (ISO 8995-89 Standard The lighting of indoor work system)
4. Do not leave any things on the machine.
5. Don't use any materials other than those recommended by the manufacturer for cutting operations on the machine.
6. Ensure that the work piece is clamped appropriately by the machine's clamp or vice
7. Ensure safe working position, always keep your balance.
8. Keep your machine always clean for safe operation. Follow the instructions at maintenance and replacement of accessories. Check the plug and cable regularly. If damaged, let it replace by a qualified electrician. Keep handles and grips free of any oil and grease.
9. Unplug first, before conducting and maintenance works.
10. Ensure that any keys or adjustment tools have been removed before operating the machine..
11. If you are required to operate the machine outside, use only appropriate extension cables.
12. Repairs should be carried out by qualified technicians only. Otherwise, accidents may occur.
13. Before starting a new operation, check the appropriate function of protective devices and tools, ensure that they work properly. All conditions have to be fulfilled in order to ensure proper operation of your machine. Damaged protective parts and equipment have to be replaced or repaired properly (by the manufacturer or dealer).
14. Don't use machines with improper functioning buttons and switches

- 15. Don't keep flammable, combustive liquids and materials next to the machine and electric connections.

3. MACHINE'S DESCRIPTION

Computerized driving conveyor helps to cutting machines to cut profiles intended dimension.

- > Windows based PLC control system with touch screen display.
- > To compose receipt manually or via computer
- > Data transfer
- > Max.used with : 250 mm.
- > Carrying capacity : 9 kg/m.
- > Min cutting lenght : 5 mm
- > SKN 300 standard conveyor lenght 3 meter (10')
- > SKN 450 ; 4,5 meter (15'), SKN 600 ; 6 meter (20') (optional)

4. TRANSPORT OF THE MACHINE



1.The transport should be done by qualified personnel only.

2.The machine should be transported by lifting with proper equipment (not touching the ground during the transport).

- 3. Unless customer requests the contrary, the machine will be delivered with wooden packaging.
- 4. Movable parts on the machine should be fixed before carrying out the transport.
- 5. The machine size and weight measurements, given the technical specification sheet.

5. INSTALLATION OF THE MACHINE

1.Preparation

- 1. The machine size and weight measurements, given the technical specification sheet.The ground, where the machine will be placed, should be even, solid enough to bear the weight of the machine.
- 2. Please open the wooden package and get out the parts attentively.
- 3. Firstly doing montage of foot group (FIGURE 1-2 NO.34,39,81,82)
- 4. Connect the panel group as figure. (FIGURE 2 NO.95)
- 5. To connect the conveyor to machine you have requested,use the output flange plate (Figure 2.NO.41). To adjust the height and uniformity of conveyor,please use the bolts on conveyor's foot (Figure 1 NO.81) and feet of table. (Figure 1 NO.39)

2. Communication Between Machine and Conveyor

<p>Cutting machine, which works together with conveyor, sends signals to conveyor regarding to cutting operation. This signal can be any kind of sensor or switch output as given below.</p>	<p>One end of the cable from sensor or switch is connected to terminal with 24V, and the other end is inserted to input 9 terminals. In this way cutting information is send from cutting machine to conveyor and the processed amount of pieces is counted.</p>
--	--



3. Connecting to Power Source

1. Electrical connection must be made by a licensed electrician.
2. The power outlet socket on the machine should be available.
3. Plug the machine to a grounded socket.
4. Mains voltage of the machine is 220 V 50/60 Hz.



5. Check the supply voltage. **The source voltage must be in accordance with the data on the machine's label.**

6. MACHINE'S SAFETY INFORMATION

1. Lifting, installation, electric maintenance of the machine should be carried out by qualified personnel only.
2. Routine maintenance and scheduled maintenance should be carried out by qualified personnel after unplugging the machine first.
3. Ensure that the machine has been cleaned, tested and maintained before starting to operate it.
4. Check the safety devices, power cable and moving parts regularly. Don't operate the machine before having replaced defective safety devices or faulty parts.
5. Keep foreign materials away from the working area of the machine, keep away from the machine's moving parts.



The safety data have been defined above. In order to prevent physical damage or damage to the equipment, please read the safety information carefully and keep the manual always in an easy accessible place.

7. OPERATION

1. Preparation

1. To connect the conveyor to machine you have requested, use the output flange plate (Figure 2.NO.41).
2. To adjust the height and uniformity of conveyor, please use the bolts on conveyor's foot (Figure 2 NO.81) and feet of table. (Figure 1 NO.39)
3. The back gauge on the conveyor doesn't comply with the continuous cutting operations

2. Operation

- Turn on the machine by positioning the main power switch to 1 (FIGURE 2 NO. 95-2).
- Computer automatically turns on, and wait for its opening.

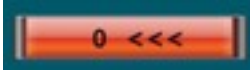

- When software starts, the screen, shown above, is appeared. Touch anywhere on the screen to leave the page.
- Before starting to work with the machine, it is necessary to identify the reference position.

- In order to identify the reference position of the machine, press  button.

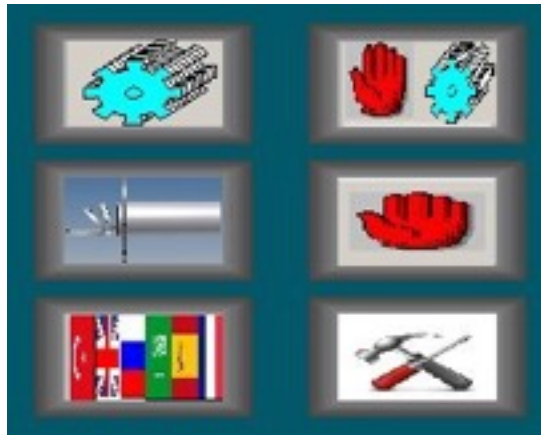

- After completing the reference determination, machine automatically displays the main menu page, shown in above figure.

SELECTION OF LANGUAGE

-  : By pressing the button shown in figure, language selection screen is opened.



- Make your selection from the popup display.

WORKING OPERATION

a. Manual Mode

- Open the the main page.

- Press on  button in appeared screen.



- The screen, shown above, appears.

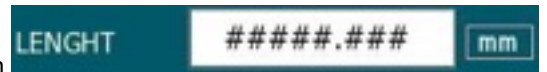

- Enter the length at which conveyor support is required to be sent in section.



- Enter the required quantity in section.
- Position the machine at demanded length by pressing on Start button.

b. Automatic mode

- Open the the main page.



- Press on button in appeared screen.



- The screen, shown above, appears.



- Recipe is displayed on the screen by using buttons. How to create recipe is described in creating recipe section.

- After displaying the recipe on the screen, press on start button and position the machine at the desired location.



- After the desired amount of pieces is cut, press on button in order to proceed to next recipe. If automatic transition between recipes are defined, when cutting operation completed, machine waits for the duration entered in the screen and proceed to next recipe, and position itself to required location.
 - Automatic transition mode is set in calibration page, as following.
 - Open main screen.

- Press on  button on the pop-up screen

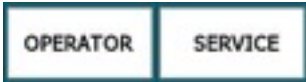
- Press on operator button in  on the pop-up screen
- Enter password (1234).

- Press on  in appeared screen. When button is pressed, switching is achieved automatically.

- Enter the required length in  section similar to manual operation mode.

c. Manual Slicing

- Open the the main page.
- Press on  button in appeared screen.

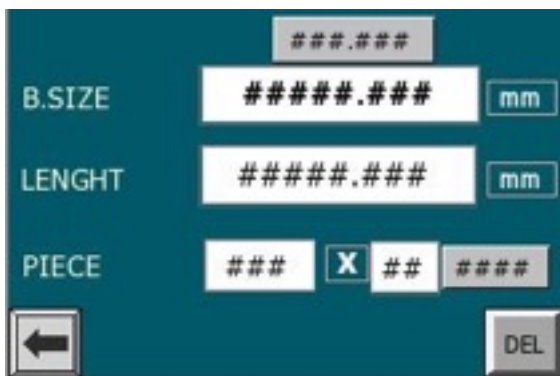

- The screen, shown above, appears.
- The total length of part mounted on the conveyor is entered in section.

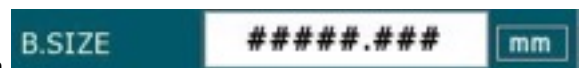

- Enter the length to be cut in  section.







- Enter the number of pieces to be cut in  section.
- Initiate cutting process by pressing on start button.
- When “Cutting finished” signal is received, conveyor waits for a while, and continue on feeding parts again.
- This process finishes either when all the quantity is processed or parts are run out of.

CREATING RECIPE

a. Creating Recipe Manually

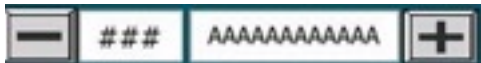
- Open the the main page.
- Press on  button in appeared screen.



- The screen, shown above, appears.
- The number of recipe that will be created is displayed on screen by using  and  buttons (Example 1)
- The name of the recipe is entered next to the number of recipe as  (Example Profile X).
- Enter the length in  section (Example 1000 mm).
- Enter the required quantity in  section (Example 2 pieces).
- Press on  after all required information is provided.
- According to above mentioned example, an entry whose recipe name is Profile X, and which requires cutting of 2 pieces of length 1000 mm is created in number 1.
- At most 800 recipes can be created by following the mentioned procedure.

MOVING CONVEYOR SUPPORT MANUALLY

- Open the the main page.

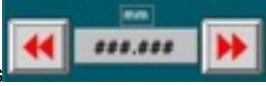
- Press on the button in figure 
- By using arrow buttons , conveyor support moves in right and left directions manually.

CALIBRATION OF CONVEYOR CUTTING DIMENSION

- Loosen the allen nuts on top of the conveyor support, move the support in far position, and then fix the nuts.
- Send conveyor support to any position (For example 500mm)
- Align the part to be processed with conveyor support, and cut with the tool at front.
- In case profile is longer than 500 mm (For example 2 mm longer)
- Open main screen.

- Press on  button on the pop-up screen

- Press on operator button in  on the pop-up screen
- Enter password (1234).

- Increase the offset value about 2 mm in appeared screen . In other words if offset is 100 mm, then edit offset value as 102 mm.

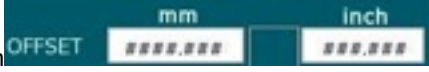
- In the case that the profile is shorter than 500 mm (For example 2 mm shorter) decrease the offset value about 2 mm in appeared screen . In other words if offset is 100 mm, then edit offset value as 98 mm.

- Move the machine to reference position by pressing on . Thus calibration settings are completed.
- If machine works in inch, same calibration procedure applies.

SELECTION OF UNIT (mm / inch)

- Open the the main page.

- Press on  button on the pop-up screen

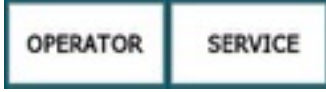
- Press on operator button in  on the pop-up screen
- Enter password (1234).

- In the displayed screen, press on  button to choose required unit.

8. MAINTENANCE, SERVICE AND REPAIR

1. Maintenance

1. Cut the electric and pneumatic (if any) power connections of the machine.
2. Clean all surfaces of the machine from burs, chips and foreign substances. If the machine will not be used for a long time, lubricate undyed parts with oil that prevents rusting.
3. When cleaning the machine, do not use materials that may damage the dye.

9. WARRANTY CONDITIONS

Tech Machine guarantees that all machines have been tested and conform to the international standards.

The guarantee is valid 24 months from despatch date and does not cover the electrical parts of the machine.

During this period:

- Any repair and replacement effected at our workshop is completely free of charge (only transport costs are at customer's charge).
- For repair and replacement effected by our technician at the customer's site, we will invoice only the travel and lodging costs for our technician.

The guarantee does not cover damages caused by:

- not respect of the rules indicated in the manual instruction book
- not correct voltage
- improper use or use not in accordance with what the Machine has been designed for
- use of non original tooling
- programming errors
- lack of cleaning and of ordinary maintenance by the customer
- transport or displacement (even inside the workshop)
- natural events (lightings, fires, floods)

The warranty does not cover, in any case, damages caused by the malfunction of the Machine

ELECTRICAL DIAGRAM

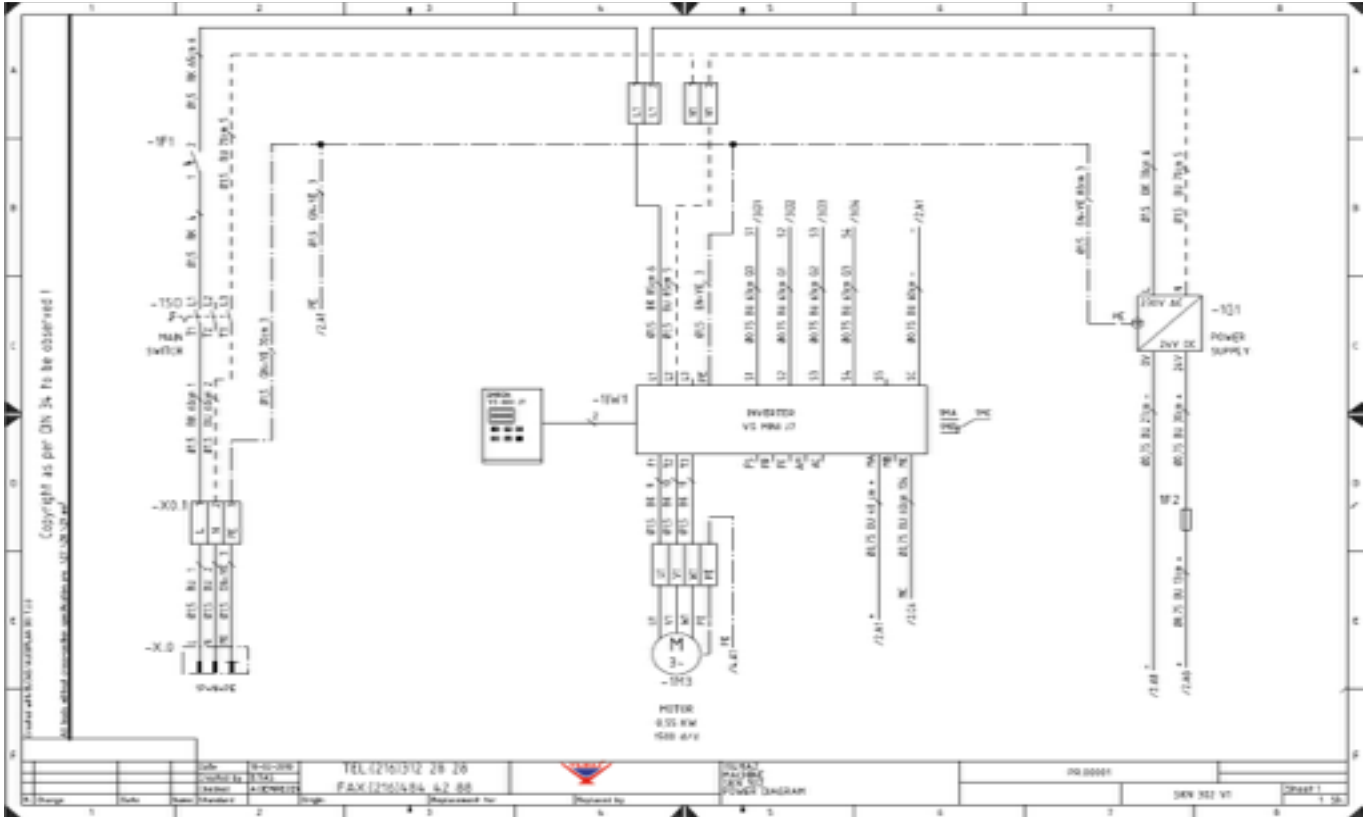

ELECTRICAL DIAGRAM SHEET 1

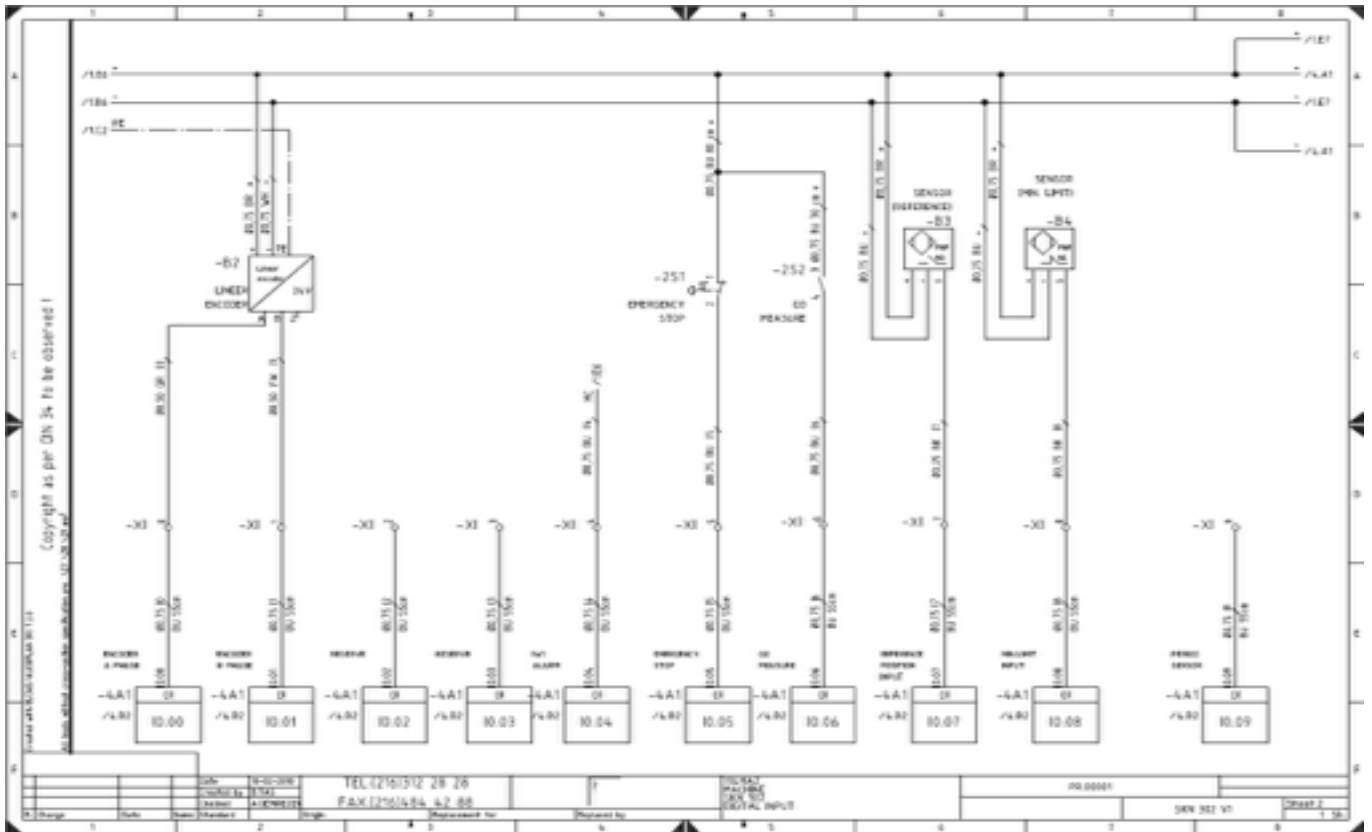

ELECTRICAL DIAGRAM SHEET 2

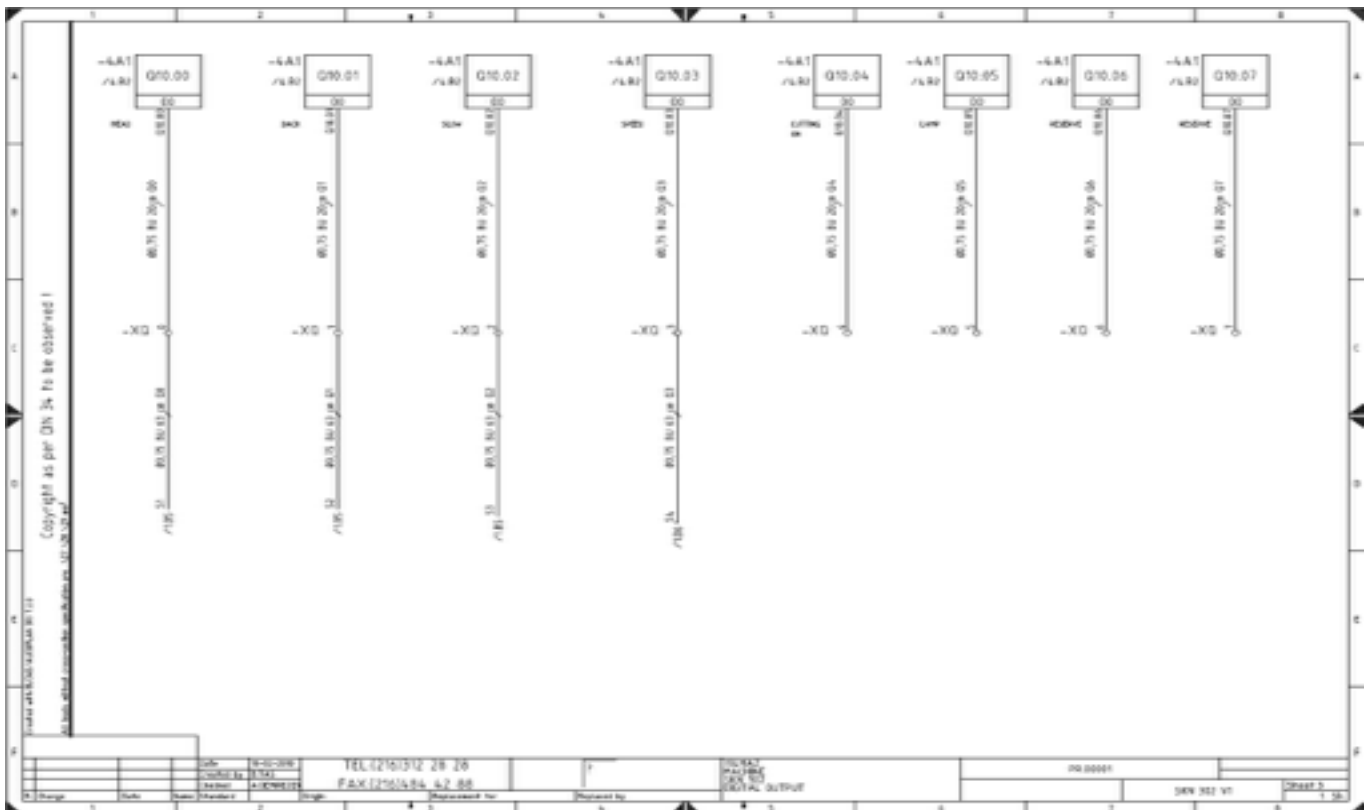

ELECTRICAL DIAGRAM SHEET 3

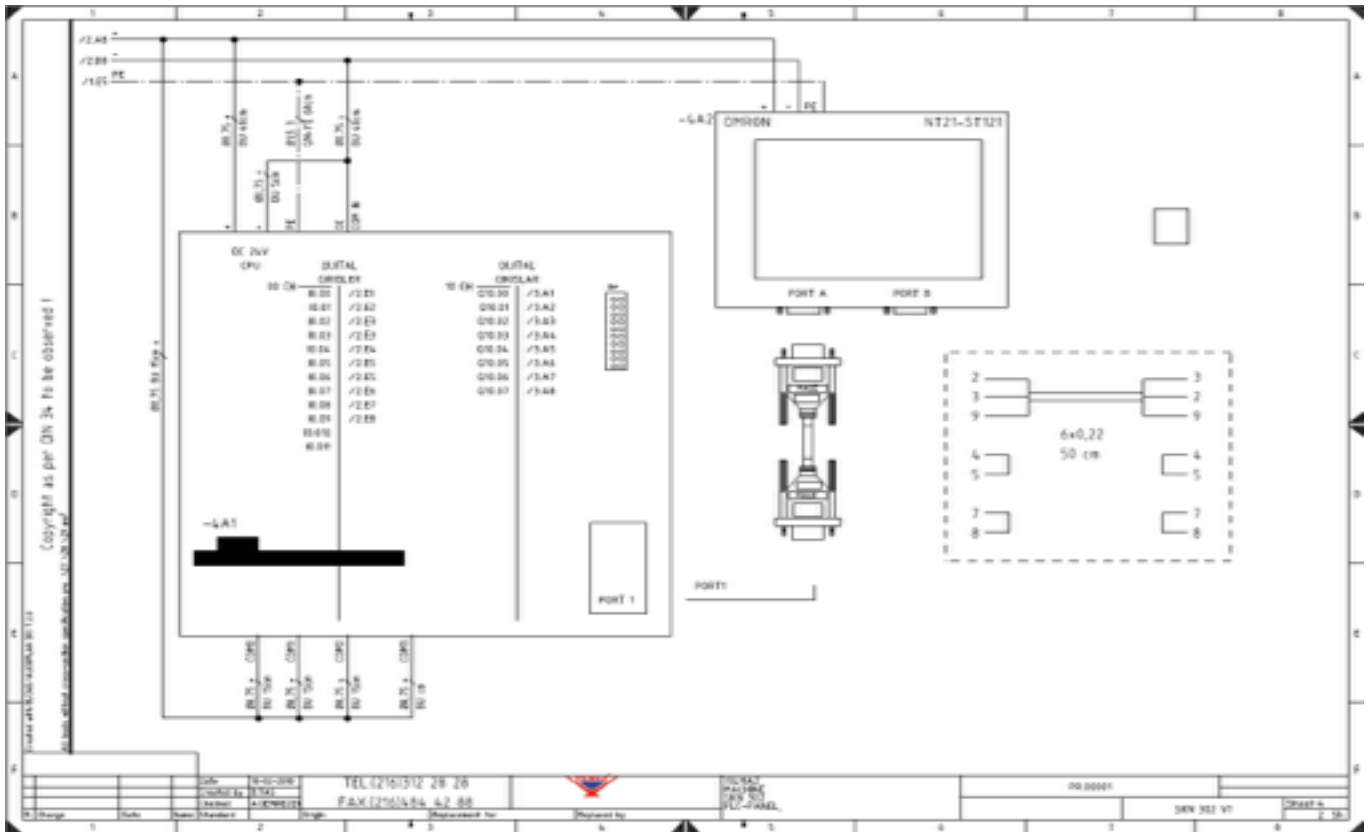

ELECTRICAL DIAGRAM SHEET 4

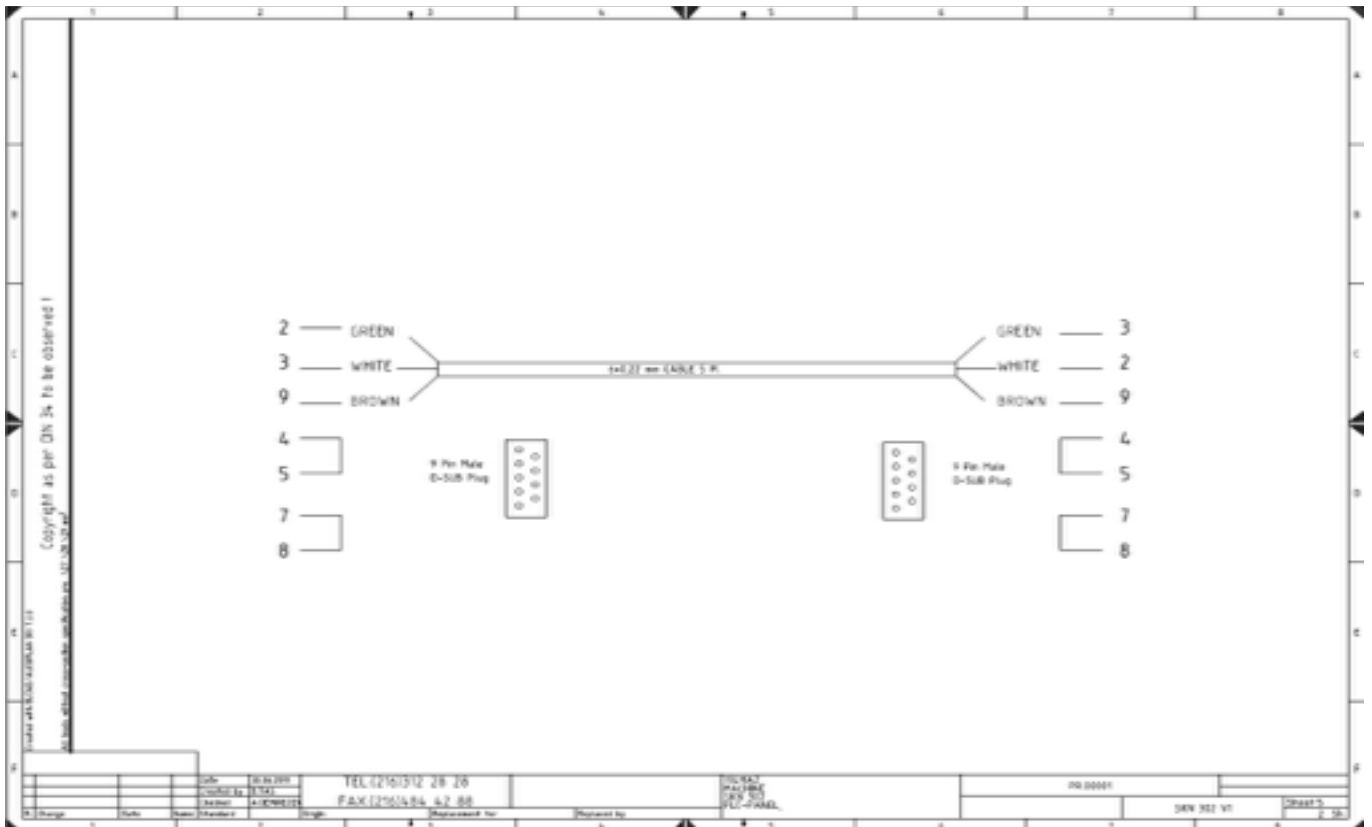

ELECTRICAL DIAGRAM SHEET 5