

atech[®]



SKAT – 06 P
16" (400 mm)



PEGASUS – 06 P
14" (350 mm)

MANUAL MITER SAW USER'S MANUAL

CONTENTS

1. GENERAL INFORMATION

- 1.1. Introduction
- 1.2. Information About The Distributor

2. MACHINE'S DESCRIPTION AND PURPOSE OF USE

- 2.1. Machine's Description
- 2.2. Technical Features
- 2.3. Cutting Diagram
- 2.4. Dimensions
- 2.5. Electrical Diagram

3. SAFETY

- 3.1. Safety Information
- 3.2. Accident Prevention
- 3.3. General Safety Information
- 3.4. Safety Symbols And Meanings

4. TRANSPORT OF THE MACHINE

5. INSTALLATION OF THE MACHINE

- 5.1. Preparation
- 5.2. Instructions About Safe Connection Of The Machine To The Power Source

6. MACHINE SAFETY DATA

7. OPERATION

- 7.1. Angular Cutting On The Table

8. SAFE INSTALLATION OF THE SAW BLADE

9. MAINTENANCE, SERVICE AND REPAIR

- 9.1. Periodic Checks And Starting To Work
- 9.2. Maintenance At The End Of The Working Day

10. INFORMATION ABOUT FAULTY USE

11. COMPONENTS

- 11.1. Electric Components

1. GENERAL INFORMATION

1.1. Introduction

The user’s manual given by the manufacturer contains information about the machine parts. Each machine operator should read these instructions carefully, and the machine should be operated after fully understanding them.

Safe and efficient use of the machine for long term depends on understanding and following the instructions contained in this manual. The technical drawings and details contained in this manual constitute a guide for the operator.

1.2. Information About The Distributor

ATech Machine, Inc.

ATechMachinery.com

Ph. : +1-240-505-1967

E-mail : info@ATechMachinery.com

*In case of any technical problem please contact your nearest ATECH dealer or ATECH head office through the above mentioned phone, fax or e-mail address.

*Technical labels with the model description of the machine are fixed onto the front side of each machine.

*The machine’s serial number and manufacturing year are stipulated on the technical label.

2. MACHINE’S DESCRIPTION AND TECHNICAL FEATURES

2.1. Machine’s Description

Portable miter saw for cutting of PVC, aluminum and wooden profiles in desired angles. The operator has the possibility to adjust the cutting speed of the saw blade via knob according to material type and size.

- Cutting at fixed angles of 15° – 22,5° – 30° – 45° – 90° and at intermediate angles via fixing arm.
- Machine has been designed according to CE Safety Directives.
- PEGASUS-06 P – SKAT-06 P : Portable manual system.
- Gas shock absorber system.
- Backstroke absorbing stop system.
- User friendly clamps. Can be tilted in the desired direction, you can tighten with a single movement.

STANDARD ACCESSORIES

- Ø350mm (14”) Carbide tipped saw blade (Pegasus)
- Ø400mm (16”) Carbide tipped saw blade (Skat)
- Twin manual clamps









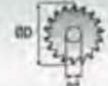

OPTIONAL ACCESSORIES

- Infeed & outfeed table
- Mechanical spring system

Please mention the below mentioned data in all your correspondence regarding the machine with the manufacturer and/or your ATECH dealer.

- Machine model
- Machine’s serial number
- Voltage and frequency
- Name of dealer where machine was purchased
- Date of purchase
- Description of the machine fault
- Average daily operation period

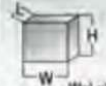
2.2. Technical Features

Pegasus-1								
ALU	PVC	WD	2.2kW, 3 HP 230 V - 400 V	D= 350 mm d= 30/32 mm	3000 r.p.m.	BAR AIR CONS.	68x65x51 cm	70
Skat-1								
ALU	PVC	WD	2.2kW, 3 HP 230 V - 400 V	D= 400 mm d= 30/32 mm	3000 r.p.m.	BAR AIR CONS.	68x65x57 cm	70

2.3. Cutting Diagram

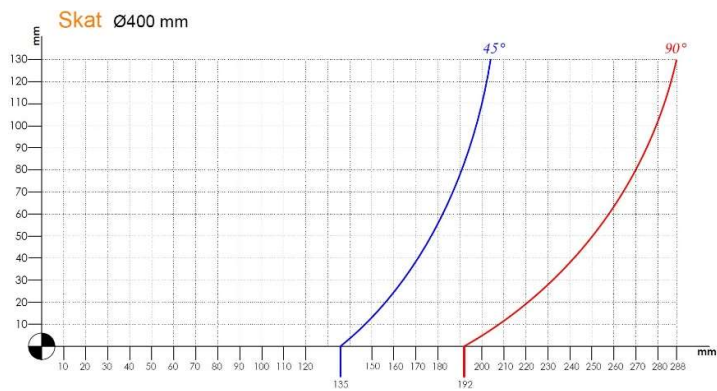
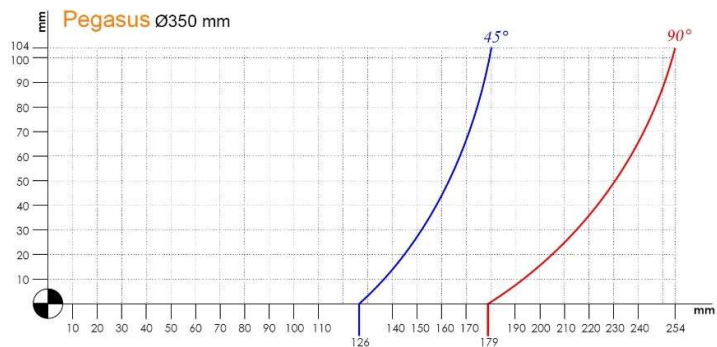

2.4. Dimensions

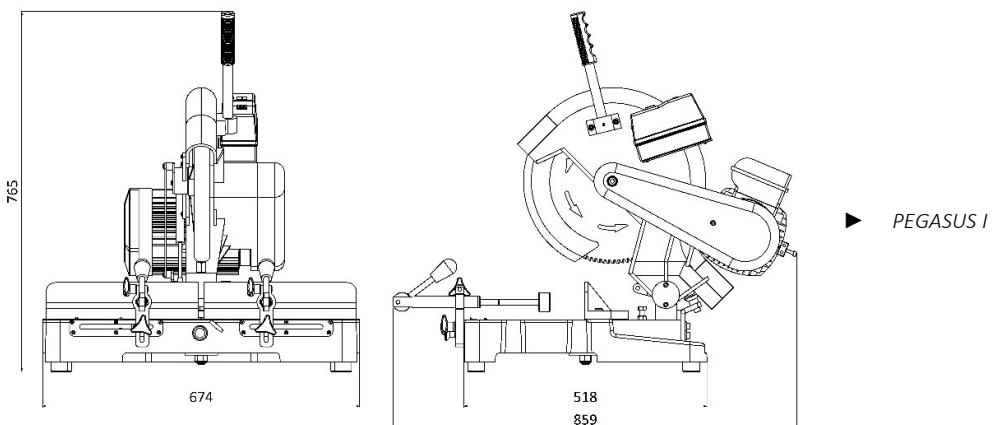
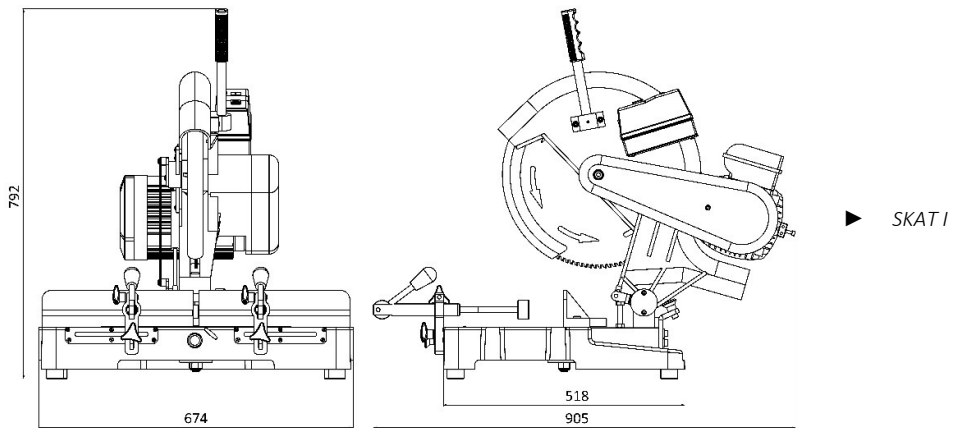

2.5. Electrical Diagram

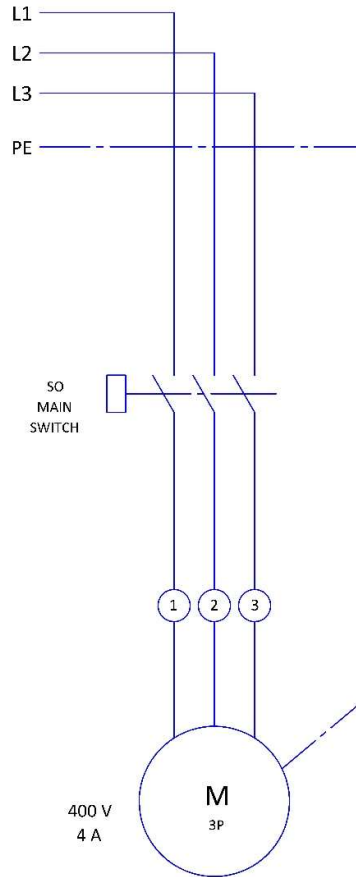

2.2 kW THREE-PHASE MOTOR

3. SAFETY

3.1. Safety Information

The symbols shown hereunder are necessary to be read with special attention. Not reading or observing of them may cause damage to the equipment or personal injury.

IMPORTANT

The **IMPORTANT** symbol above is one telling to apply special care and to be careful at carrying out the specified operation.

CAUTION!

The **CAUTION!** symbol above warns you against specific dangers and requires to read the text. Not observing may cause damage to the equipment.



The above symbol **DANGER WARNING**, warns you against specific dangers and you have definitely to read them. Negligence may cause damage to the equipment and bodily injury. Read the user's manual carefully before using the machine or carrying out maintenance works.



3.2. Accident Prevention

- 3.2.1. Our machines are manufactured in accordance with EN 60204-1 and EN 292-2 CE safety directives, which cover national and international safety directives.
- 3.2.2. It is the task of the employer to warn his staff against risks, to train them on prevention of accident, to provide for necessary safety equipment and devices for the operator's safety.
- 3.2.3. Before starting to work with the machine, the operator should check the features of the machine, learn all details of the machine's operation.

- 3.2.4. Machine should be operated only by staff members, who have read and understood the contents of this manual.
- 3.2.5. All directives, recommendations and general safety rules contained in this manual have to be observed fully. The machine cannot be operated in any way for purposes other than those described herein. Otherwise, the manufacturer shall not be deemed responsible for any damages or injuries. And such circumstances would lead to the termination of the warranty.

3.3. General Safety Information



- 3.3.1. The power cable should be led in such a way that nobody can step on it or nothing can be placed on it. Special care be taken regarding the inlet and outlet sockets.
- 3.3.2. If the power cable should be damaged during operation, don't touch and unplug it. Never use damaged power cables.
- 3.3.3. Don't overload machines for drilling and cutting. Your machine will operate more safely with power supply in accordance CE with the stipulated values.



- 3.3.4. Don't place your hands between parts in motion.
- 3.3.5. Use protective eye glasses and ear plugs. Don't wear oversized clothes and jewelry. These can be caught by moving.
- 3.3.6. Keep your working place always clean, dry and tidy for accident prevention and safe operation.
- 3.3.7. Use correct illumination for the safety of the operator. (ISO 8995-89 Standard The Lighting of Indoor Work System)
- 3.3.8. Don't leave anything on the machine.
- 3.3.9. Don't use any materials other than those recommended by the manufacturer for cutting operations on the machine.



- 3.3.10. Ensure that the work piece is clamped appropriately by the machine's clamp or vice.
- 3.3.11. Ensure safe working position, always keep your balance.
- 3.3.12. Keep your machine always clean for safe operation. Follow the instructions at maintenance and replacement of accessories. Check the plug and cable regularly. If damaged, let it be replaced by a qualified electrician. Keep handles and grips free of any oil and grease.



- 3.3.13. Unplug first, before conducting and maintenance works.
- 3.3.14. Ensure that any keys or adjustment tools have been removed before operating the machine.
- 3.3.15. If you are required to operate the machine outside, use only appropriate extension cables.





- 3.3.16. Repairs should be carried out by qualified technicians only. Otherwise, accidents may occur.
- 3.3.17. Before starting a new operation, check the appropriate function of protective devices and tools, ensure that they work properly. All conditions have to be fulfilled in order to ensure proper operation of your machine. Damaged protective parts and equipment have to be replaced or repaired properly (by the manufacturer or dealer).



- 3.3.18. Don't use machines with improperly functioning buttons and switches.
- 3.3.19. Don't keep flammable, combustible liquids and materials next to the machine and electric connections.

3.4. Safety Symbols And Meanings

	Electric warnings.		Use protective goggles.
	If main connection cable is damaged during operation, do not touch it and disconnect the main plug from main socket.		Use protective earmuffs.
	When machine is working, do not make your hand close to saw blade.		Use protective gloves when changing the saw.

	<p>Keep working environment clean, dry and tidy.</p>		<p>Read operating instructions carefully before using or maintaining the machine.</p>
---	--	---	---

4. TRANSPORT OF THE MACHINE

IMPORTANT

* The transport should be done by qualified personnel only.

- 4.1.1. The machine should be transported by lifting with proper equipment (not touching the ground during the transport).
- 4.1.2. Don't lift the machine before ensuring that lifting devices or other equipment is placed properly under the machine.

5. INSTALLATION OF YOUR MACHINE

The machine should be located at least 40 cm in front of the back wall. The machine is equipped with a burr collection bag connector and power supply socket on the back side.

5.1. Preparation

- 5.1.1. The outer dimensions of the machine are stipulated in the dimensions page. The ground, where the machine will be placed, should be even, solid enough to bear the weight of the machine.
- 5.1.2. At the miter saws PEGASUS – SKAT all parts are delivered by the manufacturer ready for use.

5.2. Instructions For Safe Connection Of The Machine To The Power Source

- 5.2.1. The three-phase power cable socket has to be in accordance with the socket on the machine.
- 5.2.2. Use a connection cable sockets in accordance with the CE Safety Directives.
- 5.2.3. Check the inlet power supply before powering the machine.

CAUTION!

The socket connections have to be made by a qualified electrician, the rotation direction of the saw blade has to be observed by starting the machine. If the saw blade rotates in reverse direction, the socket connections have to be checked and re-connected properly.

If the saw blade rotates in reverse direction, it will cause danger for the operator and the equipment.

To correct the rotation direction of the saw blade, plug in the machine and follow these instructions:

1. Press the Start button.
2. Press the cutting head down until the blade guard opens.
3. Press the Stop button. Observe the rotation direction of the saw blade through the open part of the blade guard.
4. The correct direction of the saw blade rotation is shown.

If the saw blade rotates in reverse direction: The electric socket connections have to be checked and corrected by a qualified electrician. The rotation direction of the saw blade should not be defined before testing.

6. MACHINE SAFETY DATA

- 6.1.1. It is not allowed to operate the machine with the protective cover and other protective equipment removed.
- 6.1.2. Let the electric installation of your machine carry out by a qualified electrician only.
- 6.1.3. Lifting, installation, electric, pneumatic maintenance of the machine should be carried out by qualified personnel only.
- 6.1.4. Routine maintenance and scheduled maintenance should be carried out by qualified personnel after unplugging the machine first.
- 6.1.5. Ensure that the machine has been cleaned, tested and maintenance before starting to operate.
- 6.1.6. Check the safety devices, power cable and moving parts regularly. Don't operate the machine before having replaced defective safety devices or faulty parts
- 6.1.7. Never change the circular saw without disconnecting electrical.
- 6.1.8. Keep foreign materials away from the working area of the machine, keep away from the machine's moving parts.

IMPORTANT

The saw blade continues its rotation for a while after switching off the motor.

CAUTION!

Don't use the machine for purposes other than it has been designed for (cutting of iron and other ferrous materials).

IMPORTANT

The safety data have been defined above. In order to prevent physical damage or damage to the equipment, please read the safety information carefully and keep the manual always in an easy accessible place.

7. OPERATION

The miter saws PEGASUS / SKAT cut non-ferrous aluminum, PVC profiles and PVC materials. The operator adjusts (manually via knob) the cutting speed of the saw blade according to the material type to be cut. Inner and outer sharp edges of the carbide tipped circular saw blade ensures high quality clean cutting results. The cutting length can be precisely read and adjusted using the measuring tape fixed to the back fence.

CAUTION!

Start the machine only after proper clamping of the work piece to be cut.

The machine is equipped with horizontal clamps. The clamping positions, either manual or pneumatic clamps, can be adjusted comfortably according to the material.

- At manual clamps the clamp shaft can be moved 50 mm.



The clamping cylinders have to be outside of the saw blade moving area.

Don't operate the saw while it touches the work piece. The saw must be operated only when the head is in the top position.

7.1. Angular Cutting On The Table

- 7.1.1. Press the saw blade down until it touches the cutting slot of the table.
- 7.1.2. Pull out the snap pin from its slot.
- 7.1.3. Pull the table locking Bar to the left to unlock.
- 7.1.4. Adjust the desired cutting angle by turning the handle to the right or left.
- 7.1.5. The cutting angles 15° – 22,5° – 30° – 45° are fixed by releasing the snap. Pull the table locking Bar to the right and fix the table.
- 7.1.6. At the angles 0° – 15° – 22,5° and 30°, lock the table by pulling the table locking Bar to the right. At intermediate angles (5° – 10° – 15° – 35° – 40°...etc.) the snap pin does not lock. Fix the angle just by pulling the table locking Bar to the right.

CAUTION!

Always ensure that the clamps are positioned outside of the operation area of the saw blade.

8. CHANGING THE MILLING CUTTER GROUP

To remove the circular saw blade from the blade shaft, follow the instructions below.

- 8.1.1. Disconnect the machine's electrical connection / machine completely from the plug. If there is, close the air connection.
- 8.1.2. With a screwdriver, remove the screws that connect the saw guard to the head.
- 8.1.3. Remove the M10 screw by turning with a 8 mm allen key (Hold the saw blade shaft at the opposite end with a other 8 mm allen key and prevent so that the shaft turns).
- 8.1.4. Remove the washer and Saw Flange parts regularly.
- 8.1.5. Carefully remove the saw.

CAUTION!

8.1.6. When replacing the saw with the new one, use the portion of the saw blade that corresponds to the saw blade diameter. The outer diameter of the saw ring is two sided according to 30 and 32mm.

- 8.1.7. Fit the other parts (Washer and Saw Flange) in order, following the reversal of the operations on the shaft.
- 8.1.8. Tighten the M8 screw by turning it clockwise with an 6 mm Allen key (Hold the saw blade shaft at the opposite end with a other 6 mm allen key and prevent so that the shaft turns).
- 8.1.9. With a screwdriver, tighten the screws that connect the saw guard to the head.

NOTE: The saw you use must be sharpened / changed at certain intervals depending on the type of material being cut. When the cut workpiece is burrned at the end of cutting or when the cutting is forced, sharpening / changing operation is performed.

NOTE: In this instruction, the materials used to change the saw are indicated in different colors. The saw is turquoise, the saw wheel was red, and the rest are shown in yellow.

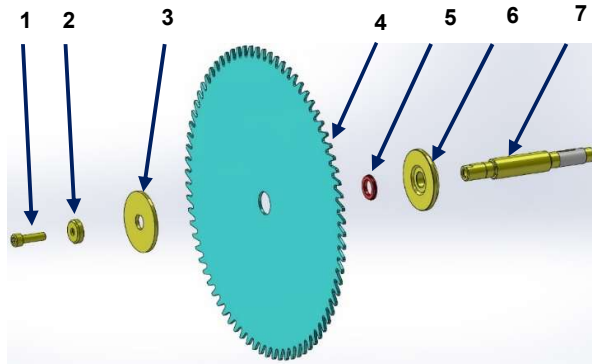

Part No	Part Name	QTY
1	Inbus M10x35	1
2	Washer 30x8x7	1
3	Saw Flange	1
4	Saw	1
5	Saw Washer	1
6	Coupling	1
7	Rotor Shaft	1

9. MAINTENANCE SERVICE AND REPAIR

9.1. Periodic Checks And Starting To Work

- 9.1.1. Ensure that the table and all kind of parts are clean and dry. Degrease and dry the table. Especially ensure that the holding grips are clean and dry.
- 9.1.2. Remove all burr, chip and foreign materials from all surfaces of the machine. Use protective eye glasses.
- 9.1.3. Check the saw blade before each use. Turn the saw blade carefully (after removing the blade guard) to see the teeth of the saw blade. Replace the saw blade if it is damaged.

CAUTION! Unplug first, before carrying out these works.

9.2. Maintenance At The End Of The Working Day

- 9.2.1. Disconnect electric connections. (Main Switch must be on "0" position)
- 9.2.2. Remove all burr, chip and foreign materials from the machine surfaces. Use gloves to protect your hands from the sharp edges of the blade.
- 9.2.3. If water or water based liquids were used during cutting, dry the machine with a dry cloth after the operation is finished.
- 9.2.4. Apply a thin layer of machine oil to protect the table against corrosion. If the machine will not be used for a long time, lubricate with a protective oil.
- 9.2.5. Don't use materials for cleaning the machine, which could damage its paint.
- 9.2.6. Lubricate both surfaces of the saw blade with machine oil in order to protect it against corrosion.

10. INFORMATION ABOUT FAULTY USE

Here are some recommendations for solving urgent problems. If the trouble cannot be solved, or if you have a problem other than those described hereunder, please contact our technical service or your nearest dealer.

TROUBLES	CAUSES	REMEDY
Low surface quality (at aluminum and similar materials); <ul style="list-style-type: none"> • Rough surface, • Large chip, • Not homogenous surface, • Saw blade traces visible 	Not cooling the saw blade surfaces	Lubricating the saw blade cutting surfaces, Using of cooling liquid.
	Using of damaged or blunt saw blade	Check the saw blade teeth. Replace if necessary.
	Saw blade moves too quick	The cutting speed is too high for the material. Decrease the cutting speed.
Motor does not work (Start button is pressed, not working)	No power supply to the machine	Check the electric cable connections. Check the electric power sockets.
The saw blade rotates in reverse direction.	The electric connection or the power cable is wrong	Let the electric connections carry out by a qualified electrician.

11. COMPONENTS

11.1. Electric Components

PART NAME	QTY
ELECTRIC MOTOR	1
MOTOR PATCHER	1
POWER CABLE 4x1,5 mm	3,5 m
ELECTRIC PLUG	1