



LIBRA-02 P

PORTABLE COPY ROUTER

USER'S MANUAL



CONTENTS	Page
1. General Information	3
1.1. Introduction	3
1.2. Manufacturer	3
2. Machine's Description and Purpose of Use	3
2.1. Machine's description	3
2.2. Technical features	5
2.3. Overall dimensions	6
2.4. Part lists and technical drawings	7
2.5. Wiring diagram	9
3. Safety	10
3.1. Safety information	10
3.2. Accident prevention	10
3.3. General safety information	11
4. Transport of the machine	13
5. Installation of the machine	13
5.1. Preparation	13
5.2. Electric connection	14
6. Machine's safety information	14
7. Operation	15
7.1. Beginning of the work	15
8. Changing the router bit	16
9. Maintenance	17
9.1. Periodic checks and maintenance at the end of the working day	17
10. Information about faulty use	17
11. Electric components	17



1. GENERAL INFORMATION

1.1. INTRODUCTION

The user's manual given by the manufacturer contains necessary information about the machine parts. Each machine operator should read these instructions carefully, and the machine should be operated after fully understanding them.

Safe and efficient use of the machine for long term depends on understanding and following the instructions contained in this manual. The technical drawings and details contained in this manual constitute a guide for the operator.

1.2. DISTRIBUTOR

ATech Machine, Inc.
10752-A Tucker Street – Beltsville, MD 20705 USA
Phone: +1-301-595-1816 Fax: +1-301-560-6627
Website: www.ATechMachinery.com E-mail: info@ATechMachinery.com

In case of any technical problem please contact your nearest ATECH dealer, or ATECH head office through the above mentioned phone fax or e-mail address.

Technical labels with the model description of the machine are fixed onto the front side of each machine.

The machine's serial number and manufacturing year are stipulated on the technical label.

2. MACHINE'S DESCRIPTION and PURPOSE OF USE

2.1. MACHINE'S DESCRIPTION

Portable copy router machine designed to open lock, handle, hinge and window fastening slots onto vinyl (PVC) and Aluminum profiles.

- Machine has been designed in accordance with the CE Safety Directives.
- Clamping and copy routing operation is carried out manually.
- Channels in different dimensions can be opened independently from copying.











Please mention the below mentioned data in all your correspondence regarding the machine with the manufacturer and/or your ATECH dealer.

- *Machine model
- *Machine's serial number
- *Voltage and frequency
- *Name of dealer where machine was purchased
- *Date of purchase
- *Description of the machine fault
- *Average daily operation period



2.2. TECHNICAL FEATURES

Technical Features (American)				
LIBRA-02 P	1200W 120V 60Hz	23000 rpm	22x22x18"	60 lb
Technical Features (Metric)				
LIBRA-02 P	1200W 230V 50Hz	23000 rpm	55x55x46 cm	27 kg



2.3. OVERALL DIMENSIONS

Figure-1

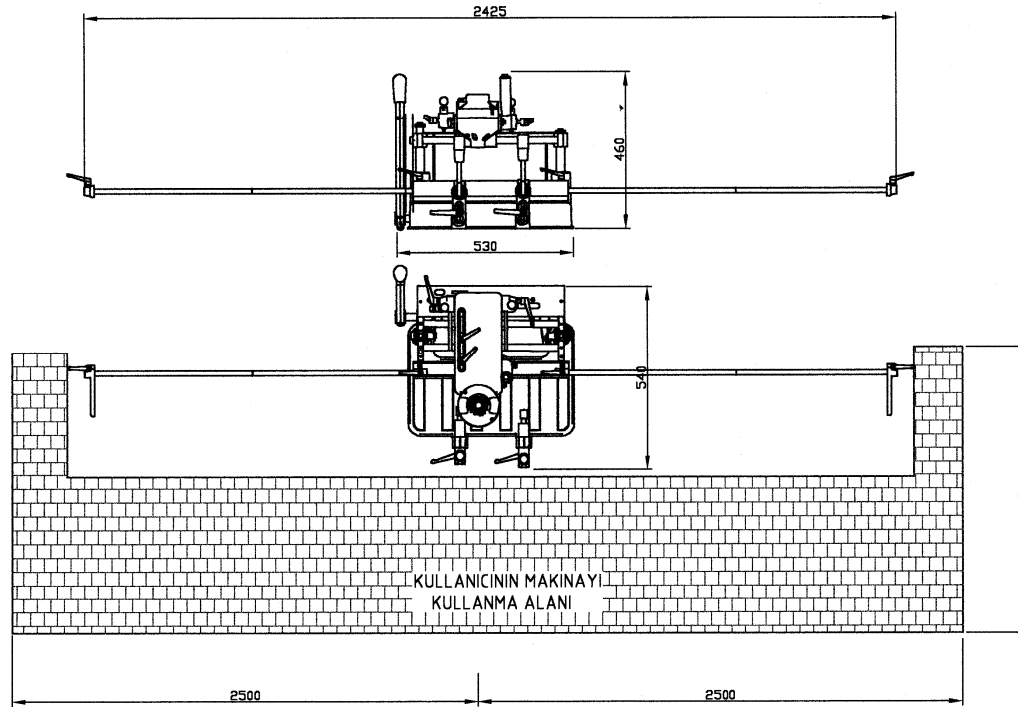

2.4. TECHNICAL DRAWINGS and PART LISTS

NO	ORDER NO.	PART NAME	QTY
1	111-062	CLAMP HOUSING	2
2	550-009	HANDLE 1	2
3	550-010	HANDLE 3	4
4	177-017		2
5	111-064	HOUSING	2
6	550-004	MECHANIC CLAMP	2
7	111-060	SET SQUARE	1
8	172-029	M8x35 HEXAG. SCREW	4
9	192-008	LINEAR BEARING25x35x40	4
10	141-138	TIGHTENING HANDLE	2
11	111-050	FOOT	1
12	224-002	FOOT PLASTIC	4
13	170-023	DIAM. 6mm WASHER	6
14	172-012	M6x20 HEXAG. SCREW	8
19	144-002	COLUMN SHAFT	2
21	111-050	COLUMN HOUSING LEFT	1
22	141-069	HOUSING SHAFT CONNECTION	2
24	172-013	M6x10 HEXAG. SCREW	6
28	180-006	M6x8 SCREW	2
29	141-060	COPY TEMPLATE	1
30	172-014	M6x16 HEXAG. SCREW	2
31	141-073	M10x170 DOWEL	1
32	176-002	M10 BOLT	3
35	141-057	12mm SUPPORT SHAFT	1
36	141-058	SUPPORT SHAFT BUSHING	2
37	141-202	TIGHTENING HANDLE	2
38	180-008	M8x12 SCREW	4
40	176-026	M8x20 HEXAG. SCREW	2
41	141-066	MOVEMENT PLATE	2
42	111-061	MOVEMENT ANKLE	2
43	172-026	M8x20 HEXAG. SCREW	2
44	172-025	M8x16 HEXAG. SCREW	2
45	172-024	M8x30 HEXAG. SCREW	4
46	193-006	25x20x20 SINTER BUSHE	2
47	141-059	LEVER SHAFT	1
48	111-065	LEVER	1
49	223-003	BAKALITE LEVER AS-3 12x15	1
	172-027	M8x25 HEXAG. SCREW	1
63	273-002	GAS SPRING 600643201 200N	1
68	171-070	GAS SPRING CONNECT.	2

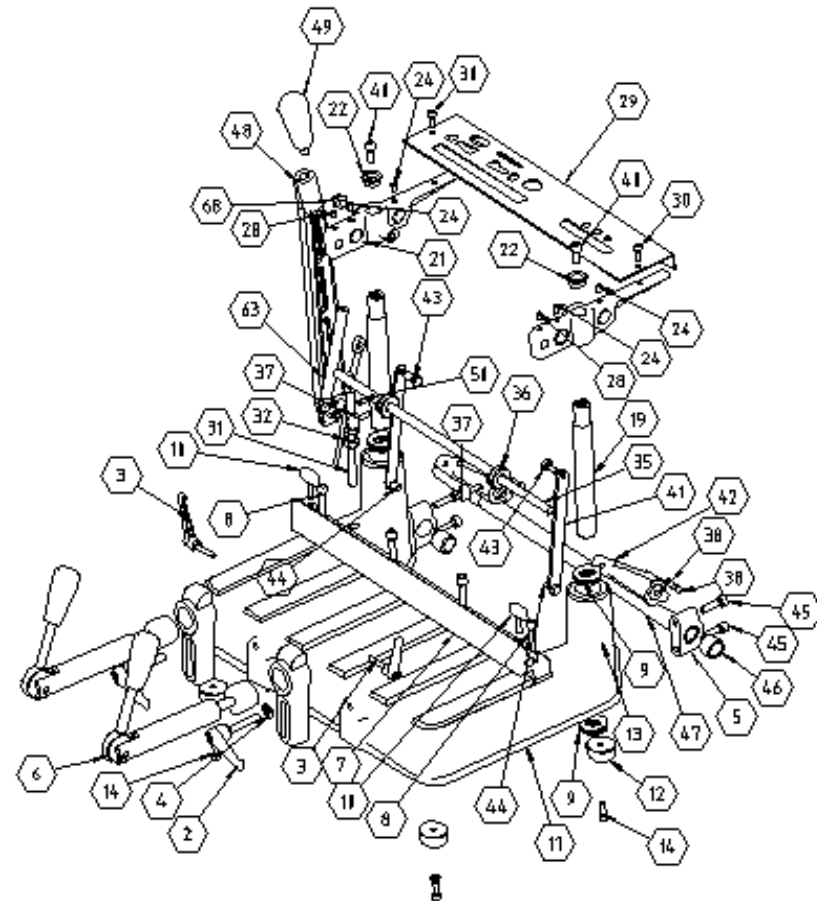
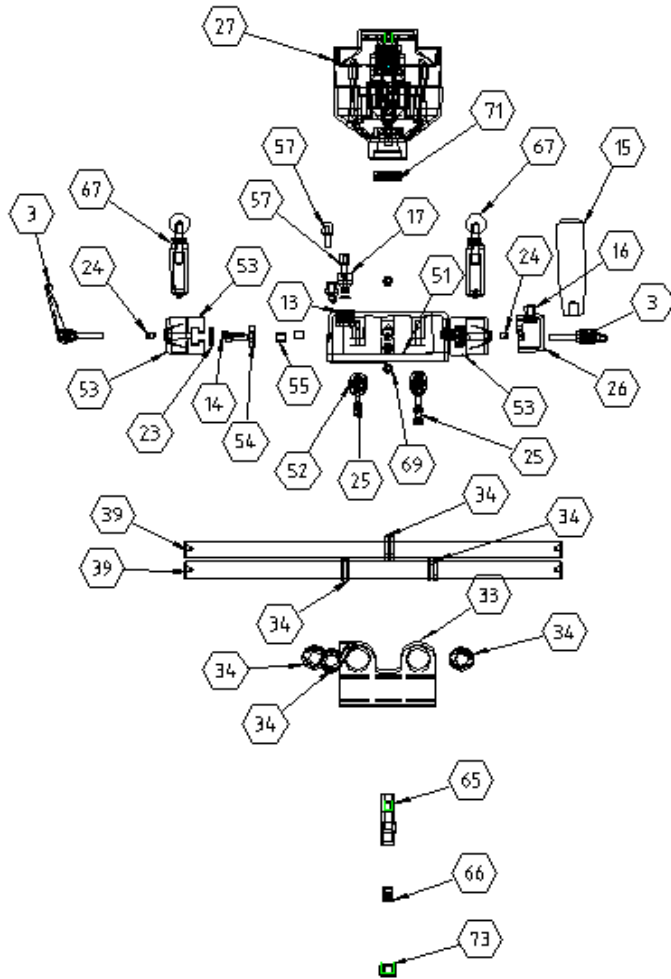

Figure-2



	ORDER	PART NAME	QTY
3	550-010	HANDLE 3	4
13	177-03	DIA 6 mm WASHER	6
14	172-012	M6x20 HEXAG. SCREW	8
15	223-004	BAKALITE LEVER A5-12	1
16	141-071	SWITCH HANDLE BOLT	1
17	141-068	UPPER LIMITING PIN	2
23	141-072	SNAP HOUSING SHEET	2
24	172-013	M6x10 HEXAG. SCREW	6
25	172-017	M6x30 HEXAG. SCREW	4
26	111-074	CONNECTOR PROTECT.	1
27	550-014	1200 W ELECTRIC MOTORU	1
33	111-059	AXIS HOUSING	1
34	192-006	LINEAR BEARING PP20x28x30	6
39	144-003	AXIS BEARING HOUSING	2
51	111-054	HEAD	1
52	144-004	UPPER AXIS SHAFT	2
53	111-068	SNAP HOUSING	2
54	145-017	SNAP HOUSING FIX. PLATE	2
55	141-175	INTERMEDIATE BUSHE	4
57	141-136	BUTTERFLY SCREW	2
65	141-062	ROUTER BIT HOLDER SHAFT	1
66	141-063	ROUTER BIT HOLDER	1
67	550-011	SNAP GROUP	2
69	176-014	FIBER BOLT	2
71	191-001	6002 2Z BEARING	1
73	141-061	ROUTER BIT HOLDER BOLT	1

Figure-3

2.6. WIRING DIAGRAM

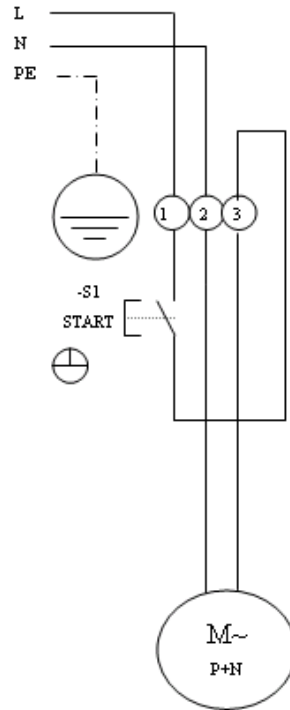

Illustration-1



3. SAFETY

3.1. SAFETY INFORMATION

The symbols shown hereunder are necessary to be read with special attention. Not reading or observing of them may cause damage to the equipment or personal injury

IMPORTANT

The **IMPORTANT** symbol above is one telling to apply special care and to be careful at carrying out the specified operation.

CAUTION !

The **CAUTION!** Symbol above warns you against specific dangers, and requires to read the text. Not observing may cause damage to the equipment.



DANGER WARNING

The **DANGER WARNING** above warns you against specific dangers, and definitely requires the text to read. Not observing may result in serious bodily injury.

Please read the user's manual carefully before using the machine or carrying out maintenance.



3.2. PREVENTION OF ACCIDENTS

3.2.1 Our machines are manufactured in accordance with EN 60204-1 and EN 292-2 CE safety directives, which cover national and international safety directives.

3.2.2 It is the task of the employer to warn his staff against accident risks, to train them on prevention of accidents, to provide for necessary safety equipment and devices for the operator's safety.

3.2.3 Before starting to work with the machine, the operator should check the features of the machine, learn all details of the machine's operation.

3.2.4 The machine should be operated only by staff members, who have read and understood the contents of this manual.

3.2.5 All directives, recommendations and general safety rules contained in this manual have to be observed fully. The machine cannot be operated in any way for purposes other than those described herein. Otherwise, the manufacturer shall not be deemed responsible for any damages or injuries. And such circumstances would lead to the termination of the warranty.

3.3. GENERAL SAFETY INFORMATION



3.3.1. The power cable should be led in such a way that nobody can step on it or nothing can be placed on it. Special care has to be taken regarding the inlet and outlet sockets.



3.3.2. If the power cable should be damaged during operation, don't touch and unplug it. Never use damaged power cables.

3.3.3. Don't overload machines for drilling and cutting. Your machine will operate more safely with power supply in accordance with the stipulated values.



3.3.4. Don't place your hands between parts in motion.



3.3.5. Use protective eye glasses and ear plugs. Don't wear oversize clothes and jewels. These can be caught by moving parts.



3.3.6. Keep your working place always clean, dry and tidy for accident prevention and safe operation.

3.3.7. Use correct illumination for the safety of the operator. (ISO 8995-89 The Lighting of Indoor Work Systems)

3.3.8. Don't leave anything on the machine.

3.3.9. Don't use any materials other than those recommended by the manufacturer for cutting operations on the machine.

3.3.10. Ensure that the work piece is clamped appropriately by the machine's clamp or vice.



3.3.11. Ensure safe working position, always keep your balance.

3.3.12. Keep your machine always clean for safe operation. Follow the instructions at maintenance and replacement of accessories. Check the plug and cable regularly. If damaged, let it replace by a qualified electrician. Keep handles and grips free of any oil and grease.

3.3.13. Unplug first, before conducting and maintenance works.

3.3.14. Ensure that any keys or adjustment tools have been removed before operating the machine.

3.3.15. If you are required to operate the machine outside, use only appropriate extension cables.

3.3.16. Repairs should be carried out by qualified technicians only. Otherwise, accidents may occur.

3.3.17. Before starting a new operation, check the appropriate function of protective devices and tools, ensure that they work properly. All conditions have to be fulfilled in order to ensure proper operation of your machine. Damaged protective parts and equipment have to be replaced or repaired properly (by the manufacturer or dealer).

3.3.18. Don't use machines with improper functioning buttons and switches.

3.3.19. Don't keep flammable, combustive liquids and materials next to the machine and electric connections.

4. TRANSPORT OF THE MACHINE

IMPORTANT

- 4.1.1. The transport should be done by qualified personnel only.
- 4.1.2. The machine should be transported by lifting with proper equipment (not touching the ground during the transport).
- 4.1.3. Movable parts on the machine should be fixed before carrying out the transport through the support shaft fixing bushing (Figure-5, No. 36).
- 4.1.4. Please keep the original packing of the machine for use at future transports.

5. INSTALLATION OF THE MACHINE

5.1. PREPARATION

- 5.1.1. The machine's overall dimensions are given under Figure 1. Place the machine onto an even ground, or onto the double tray tool cabinet delivered as optional equipment.
- 5.1.2. The machine should be located approx. 30 cm away from the rear wall. The power connection plug of the machine is located on the rear side of the machine.
- 5.1.3. The machine should be placed on even and solid ground.
- 5.1.4. At our portable copy router model LIBRA-02 P, connect the profile support bars by screwing the bars No. 74 and 75 into each other (Figure-5). Fix the set square fence No. 76 with the special screw No. 3 onto the support bars. Insert the assembled support bars into the slot on the set square No. 7, and tighten with the special screw No. 10.

No	Stock No / Part name	QTY
3	150-010 HANDLE 1	5
7	111-060 SQUARE	1
10	141-138 TIGHTENING HANDLE	2
15	223-004 BUTTON SWITCH	1
36	141-058 SUPPORTING PIVOT FIXED PART	2
48	111-065 ARM	1
74	141-065 SQUARE SUPPORTING PIVOT 1	1
75	141-064 SQUARE SUPPORTING PIVOT 2	1
76	111-055 SQUARE SUPPORT	1

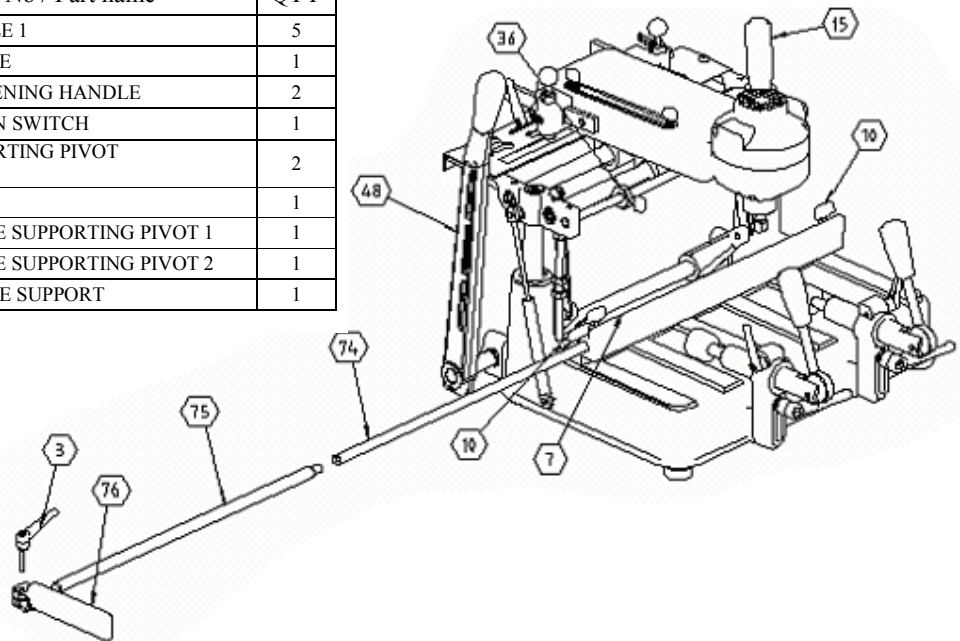

Figure-5



5.2. ELECTRIC CONNECTION

5.2.1 The electric cable socket has to be in accordance with the socket on the machine.

5.2.2 Your machine has to be used with 230V 50Hz voltage.

5.2.3 Use the machine's plug with a grounded socket.

CAUTION !

5.2.4. Check the supply voltage. The source voltage must be in accordance with the data on the machine's label.

6. MACHINE'S SAFETY INFORMATION

6.1.1. The machine should not be used without the transparent protection shield in front of the router bit.

6.1.2. Lifting, installation, electric maintenance of the machine should be carried out by qualified personnel only.

6.1.3. Routine maintenance and scheduled maintenance should be carried out by qualified personnel after unplugging the machine first.

6.1.4. Ensure that the machine has been cleaned, tested and maintained before starting to operate it.

6.1.5. Check the safety devices, power cable and moving parts regularly. Don't operate the machine before having replaced defective safety devices or faulty parts.

6.1.6. Never replace the router bit before unplugging the machine first.

6.1.7. Keep foreign materials away from the working area of the machine, keep away from the machine's moving parts.

IMPORTANT

The safety data have been defined above. In order to prevent physical damage or damage to the equipment, please read the safety information carefully and keep the manual always in an easy accessible place.

7. OPERATION

7.1. BEGINNING OF THE WORK

7.1.1. Ensure that the machine table and all kind of parts are clean and dry. Degrease and dry the machine table. Especially ensure that the holding grips and handles are clean and dry.

7.1.2. Clean all surfaces of the machine from chip and foreign particles. Use eye glasses for protection.

7.1.3. Check with the appropriate keys that the router bit is tightened properly.

7.1.4. Check the router bit for wear, bending and breaking. Replace them if damaged.

7.1.5. The portable copy router machine LIBRA is used for opening of key lock shapes, hinge slots, window fastening slots and holes, slot channels in different dimensions independently from the copying onto non-ferrous aluminum materials and hard plastic materials or wood.

7.1.6. Fix the aluminum or PVC profile, which you want to process, with the fixed clamps on the machine table. Chose the shape on the copy template, which you want to copy onto the profile.

7.1.7. Keep the switch button on the movable head pressed (Figure 5, No. 15) to rotate the router bit.

7.1.8. Keep the switch button on the movable head pressed (Figure 5, No. 15) to rotate the router bit. At the same time, move the arm inside the shape slot to copy the selected shape onto the profile. Push the arm (Figure 5, No. 15) down as far as it is necessary for the routing operation on the profile.

CAUTION !

7.1.9. At the end of the copying operation, release the Start button. The router bit will come to a full stop within approx. 10 sec. After releasing the button.

7.1.10. Open the clamps and take out the processed part.

7.1.11. The machine is equipped with horizontal clamps. These horizontal clamps can be easily adjusted according to the profile.

CAUTION !

7.1.12. Do not process the profile before clamping the work piece properly.

7.1.13. The router bit should be moved down only after the regular rotation has been reached.

8. CHANGING THE ROUTER BIT

8.1.1 If it becomes necessary to replace the router bit for any reason, follow the following order for replacement:



8.1.2. Unplug the machine

8.1.3. Loosen the nut shown in Figure 4, No. 52 and 51, using 2 wrench keys 14 and 17 mm, turning it in counter clockwise direction. Take out the router bit from its holder. Insert the new router bit into the router bit holder, and tighten the nut.

NOTE: Ensure that the router bit is fixed properly.

CAUTION !

8.1.4. Check the router bit before using it. The router bit has to be inserted into the holder properly. Don't use damaged router bits with improper function. Operate the machine for at least 30 seconds to be sure that the router bit has been inserted and fixed correctly.

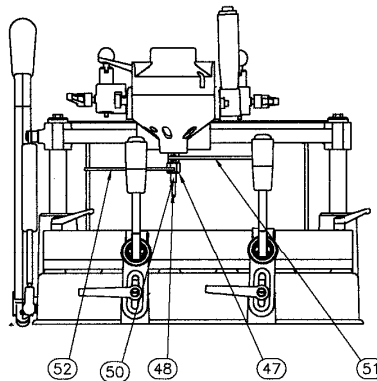

Figure-4



9. MAINTENANCE

9.1. PERIODIC CHECKS AND MAINTENANCE AT THE END OF THE WORKING DAY

9.1.1. Unplug the machine first.

9.1.2. Remove all burr, foreign materials from the machine's surface. Use protective eye glasses.

9.1.3. Clean and dry the machine table.

9.1.4. When cleaning the machine, don't use any materials which could cause damage to the machine's paint.

10. INFORMATION ABOUT FAULTY USE

10.1.1. Check the plug for power supply.

10.1.2. Keep the button pressed for continuous turning of the router bit until the end of the operation.

10.1.3. This machine is used for opening of slots, channels in various dimensions onto PVC, aluminum profiles and wooden materials.

11. ELECTRIC COMPONENTS

ORDER NO.	PART NAME	QUANTITY
550-014	MOTOR 1200W 230V 50 Hz	1
165-019	PUSH BUTTON DD22 TS	1
164-015	3x1 PRINTED PLUG	1
165-019	CONNECTOR 1 NO TRIPLE	1